

HOMOLOGY SPHERES YIELDING LENS SPACES

MOTOO TANGE

ABSTRACT. It is known by the author that there exist 20 families of Dehn surgeries in the Poincaré homology sphere yielding lens spaces. In this paper, we give the concrete knot diagrams of the families and extend them to families of lens space surgeries in Brieskorn homology spheres. We illustrate families of lens space surgeries in $\Sigma(2, 3, 6n \pm 1)$ and $\Sigma(2, 2s + 1, 2(2s + 1)n \pm 1)$ and so on. As other examples, we give lens space surgeries in graph homology spheres, which are obtained by splicing two Brieskorn homology spheres.

1. INTRODUCTION

1.1. Lens space surgeries and double-primitive knots. We define lens space $L(p, q)$ to be the $+p/q$ -surgery of the unknot in S^3 . Let Y be a homology sphere. If a knot $K \subset Y$ yields a lens space by some (positive) integral Dehn surgery, we say that $K \subset Y$ admits (positive) lens surgery. If in general the surgered manifold is e.g., Seifert manifold, we say the surgery *Seifert surgery* and so on. We write p -surgery of $K \subset Y$ as $Y_p(K)$. If K admits lens space surgery or Seifert surgery, then such a knot K is called *lens space knot* or *Seifert space knot* respectively. The number p of the Dehn surgery $Y_p(K)$ is called *slope* and $[\tilde{K}] \in H_1(Y_p(K))$ is called *dual class* in this paper. *Throughout this paper, any slope is a positive integer if there are no special statements.* Here $\tilde{K} \subset Y_p(K)$ is dual knot (i.e., core circle of the attached solid torus) of the surgery. We call the pair of slope and dual class (e.g., *lens surgery or Seifert surgery parameter*), depending on the surgered manifold.

As examples of lens space knots in S^3 it is well-known that there are the torus knots, some cable knots of torus knots and some hyperbolic knots and so on. Berge in [3] defined double-primitive knot in S^3 which generalizes these examples. Here we define double-primitive knot in a general way.

Definition 1.1 (Double-primitive knot). Let Y be a homology sphere with at most 2 Heegaard genus. Suppose $K \subset Y$ is a knot and $H_0 \cup_{\Sigma_2} H_1$ is a genus 2 Heegaard decomposition of Y , where each H_i is the genus 2 handlebody and Σ_2 is the Heegaard surface. If $K \subset Y$ is isotopic to a knot K' satisfying the following conditions, then K is called a *double-primitive knot*.

- K' lies in Σ_2 .
- For $i = 0, 1$ the induced elements $[K'] \in \pi_1(H_i) \cong F_2$ (the rank 2 free group) are both primitive elements in F_2 .

The main ideas by Berge in [3] are the definition of double-primitive knots and the two basic facts which are written below.

Fact 1.1. *Any double-primitive knot is a lens space knot.*

The Dehn surgery by the surface slope for the genus two surface gives rise to a Heegaard genus one manifold, because of double-primitive condition. This is

Key words and phrases. Lens space surgery, (1,1)-simple knot, homology sphere, Brieskorn homology sphere, graph homology sphere.

This research was supported by JSPS KAKENHI Grant-in-Aid for Young Scientists (Start-up) Grant Number 19840029 and (B) Grand Number 17K14180.

the easy proof for this fact. Note that even if a homology sphere which includes a double-primitive knot is not S^3 , then the double-primitive knot becomes a lens space knot. Gordon conjectured that double-primitive knots in S^3 are all of lens space knots in S^3 . This conjecture is known as *Berge conjecture* (Problem 1.78 in Kirby's problem list [7]). This conjecture is open so far. Any simple (1,1)-knot $\tilde{K}_{p,k}$ in a lens space gives an integral \mathbb{Z} HS surgery uniquely (read Section 2). We denote by $K_{p,k}$ the dual knot. \mathbb{Z} HS is the abbreviation of integral homology sphere. The following is a second basic fact:

Fact 1.2. *For relatively prime positive integers p, k , the dual knot $K_{p,k}$ of simple (1,1)-knot in a lens space is a double-primitive knot in a homology sphere.*

The dual means the core circle of the integral \mathbb{Z} HS surgery of $\tilde{K}_{p,k}$. By taking the union of the neighborhood of $K_{p,k}$ and one solid torus with respect to the Heegaard decomposition of $L(p, q)$, one can understand this fact. For example, see [12]. These terminologies will be defined in Section 2 in this paper. The reason for us to restrict lens space knot to $K_{p,k}$ is to control the homology sphere containing a lens space knot. In fact in many cases, the homology sphere $Y_{p,k}$ containing $K_{p,k}$ can be Seifert homology sphere and the Heegaard genus is at most two. For example, if one considers more general homology sphere surgery of a lens space, the obtained homology sphere is complicated in general (possibly it may be a higher Heegaard genus \mathbb{Z} HS).

Berge in [3], furthermore, listed $K_{p,k}$ in S^3 . We call these knots *Berge knots* here. The examples are organized as in TABLE 1 (due to Rasmussen [11]). The integer p is the slope (positive integer) and k is the dual class of lens space surgery.

Note that as long as we deal with a lens space surgery of a homology sphere, the dual class k is regarded as an integer with $0 < k < p/2$ canonically up to taking the inverse in the multiplicative group $(\mathbb{Z}/p\mathbb{Z})^\times$ and multiplying it by -1 .

Furthermore, if a pair of coprime integers (p, k) is given, it uniquely determines a dual knot $K_{p,k}$ of simple (1,1)-knot in a lens space with the lens surgery parameter (p, k) . $K_{p,k}$ lies in a homology sphere $Y_{p,k}$. In other words, $K_{p,k}$ is a representative in lens space knots with the parameter (p, k) .

Greene in [5] proved if a lens space is constructed by an integral Dehn surgery of a knot K in S^3 , then there exists a Berge knot B such that the parameter of B is the same as the one of K . This implies that Berge knots include all double-primitive knots in S^3 . Namely TABLE 1 is the table of the parameters (p, k) of double-primitive knots in S^3 .

Type	p	k	Condition
I	$ik \pm 1$	k	$(i, k) = 1$
II	$ik \pm 1$	k	$(i, k) = 2$
III	$\pm(2k \mp 1)d (k^2)$	k	$d k \pm 1, \frac{k \pm 1}{d}$ odd
IV	$\pm(k \mp 1)d (k^2)$	k	$d 2k \pm 1$
V	$\pm(k \mp 1)d (k^2)$	k	$d k \pm 1, d$ odd
VII, VIII	p	k	$k^2 \pm k \pm 1 = 0 (p)$
IX	$22\ell^2 + 9\ell + 1$	$11\ell + 2$	$\ell \in \mathbb{Z}$
X	$22\ell^2 + 13\ell + 2$	$11\ell + 3$	$\ell \in \mathbb{Z}$

TABLE 1. A list of Berge knots due to Rasmussen [11].

The author in [14] found a list of 20 families of $K_{p,k}$ with $Y_{p,k} = \Sigma(2, 3, 5)$ that the positive p -surgery of $K_{p,k}$ is a lens space $L(p, k^2)$. The families consist of 19

quadratic families and 1 isolated example as illustrated in TABLE 2. The ℓ is a non-zero integer and k_2 is the integer with $kk_2 \equiv \pm 1 \pmod{p}$ and $0 < k_2 < p/2$. The g' stands for $2g(K) - p - 1$. It is an open question whether the table lists all $K_{p,k}$'s with $Y_{p,k} = \Sigma(2, 3, 5)$ or not, which it would be Greene's type statement if the question is yes. It is conjectured that TABLE 2 lists all $K_{p,k}$'s with $Y_{p,k} = \Sigma(2, 3, 5)$ with

Type	p	k	k_2	g'
A ₁	$14\ell^2 + 7\ell + 1$	$7\ell + 2$	$14\ell + 3$	$- \ell $
A ₂	$20\ell^2 + 15\ell + 3$	$5\ell + 2$	$20\ell + 7$	$- \ell $
B	$30\ell^2 + 9\ell + 1$	$6\ell + 1$	$15\ell + 2$	$- \ell $
C ₁	$42\ell^2 + 23\ell + 3$	$7\ell + 2$	$42\ell + 11$	$- \ell $
C ₂	$42\ell^2 + 47\ell + 13$	$7\ell + 4$	$42\ell + 23$	$- \ell $
D ₁	$52\ell^2 + 15\ell + 1$	$13\ell + 2$	$52\ell + 7$	$- \ell $
D ₂	$52\ell^2 + 63\ell + 19$	$13\ell + 8$	$52\ell + 31$	$- \ell $
E ₁	$54\ell^2 + 15\ell + 1$	$27\ell + 4$	$54\ell + 7$	$- \ell $
E ₂	$54\ell^2 + 39\ell + 7$	$27\ell + 10$	$54\ell + 19$	$- \ell $
F ₁	$69\ell^2 + 17\ell + 1$	$23\ell + 3$	$69\ell + 8$	$-2 \ell $
F ₂	$69\ell^2 + 29\ell + 3$	$23\ell + 5$	$69\ell + 14$	$-2 \ell $
G ₁	$85\ell^2 + 19\ell + 1$	$17\ell + 2$	$85\ell + 9$	$-2 \ell $
G ₂	$85\ell^2 + 49\ell + 7$	$17\ell + 5$	$85\ell + 24$	$-2 \ell $
H ₁	$99\ell^2 + 35\ell + 3$	$11\ell + 2$	$99\ell + 17$	$-2 \ell $
H ₂	$99\ell^2 + 53\ell + 7$	$11\ell + 3$	$99\ell + 26$	$-2 \ell $
I ₁	$120\ell^2 + 16\ell + 1$	$12\ell + 1$	$20\ell + 1$	$-2 \ell $
I ₂	$120\ell^2 + 20\ell + 1$	$20\ell + 2$	$30\ell + 2$	$-2 \ell $
I ₃	$120\ell^2 + 36\ell + 3$	$12\ell + 2$	$30\ell + 4$	$-2 \ell $
J	$120\ell^2 + 104\ell + 22$	$12\ell + 5$	$20\ell + 9$	$- 2\ell + 1 $
K	191	15	51	-2

TABLE 2. $K_{p,k}$ for each (p, k) is a lens space knot in the Poincaré homology sphere yielding $L(p, k^2)$.

$2g(K) < p + 1$. The similar conjecture is Conjecture 1 in [11]. This genus restriction is needed because as mentioned in [14], there is a counterexample. For a partial circumstantial evidence for this conjecture, for example see [16]. On the other hand, in [15] it is shown that $-\Sigma(2, 3, 5)$ never admit any positive lens space knot and $\Sigma(2, 3, 5) \# (-\Sigma(2, 3, 5))$ never have any lens space knots. Our main question is the following:

Question 1.1. Which homology spheres other than S^3 or $\Sigma(2, 3, 5)$ include a double-primitive knot? Does such a homology sphere have a list analogous to TABLE 1 or 2?

1.2. Tables of lens space surgeries in Brieskorn homology spheres. In this paper we mainly focus on $K_{p,k}$ in some Brieskorn homology spheres and some graph homology spheres. We give a table of $K_{p,k}$ in $\Sigma(2, 3, 7)$.

Theorem 1.3. TABLE 3 is a collection of examples of $K_{p',k}$ with $Y_{p',k} = \Sigma(2, 3, 7)$. The positive p' -surgery of $K_{p',k}$ gives the lens space $L(p', k^2)$ in the table. Here ℓ in the table is a non-zero integer.

We conjecture the following statement on the genus $g(K_{p',k})$.

Conjecture 1.4. The genus $g(K_{p',k})$ for (p', k) which is any parameter in TABLE 3 is $(g' + p' + 1)/2$, where g' is the value in the table.

As one can see, TABLE 3 is parallel to TABLE 2. The slope p in TABLE 2 corresponding slope p' is related by the formula by the last column in TABLE 3. For example, on the type A_1 , between corresponding two lens space surgeries, the formula $(p+p')/2 = (4\ell+1)^2$ is satisfied. Here we address the following conjectures

Type	p'	k	g'	$\frac{p'+p}{2}$
A_1	$18\ell^2 + 9\ell + 1$	$9\ell + 2$	$ \ell $	$(4\ell + 1)^2$
A_2	$30\ell^2 + 25\ell + 5$	$5\ell + 2$	$ \ell $	$(5\ell + 2)^2$
B	$42\ell^2 + 15\ell + 1$	$6\ell + 1$	$ \ell $	$(6\ell + 1)^2$
C_1	$56\ell^2 + 33\ell + 5$	$7\ell + 2$	$ \ell $	$(7\ell + 2)^2$
C_2	$56\ell^2 + 65\ell + 19$	$7\ell + 4$	$ \ell $	$(7\ell + 4)^2$
D_1	$76\ell^2 + 17\ell + 1$	$19\ell + 2$	$ \ell $	$(8\ell + 1)^2$
D_2	$76\ell^2 + 97\ell + 31$	$19\ell + 12$	$ \ell $	$(8\ell + 5)^2$
E_1	$74\ell^2 + 17\ell + 1$	$37\ell + 4$	$ \ell $	$(8\ell + 1)^2$
E_2	$74\ell^2 + 57\ell + 11$	$37\ell + 14$	$ \ell $	$(8\ell + 3)^2$
F_1	$93\ell^2 + 19\ell + 1$	$31\ell + 3$	$ 2\ell $	$(9\ell + 1)^2$
F_2	$93\ell^2 + 43\ell + 5$	$31\ell + 7$	$ 2\ell $	$(9\ell + 2)^2$
G_1	$115\ell^2 + 21\ell + 1$	$23\ell + 2$	$ 2\ell $	$(10\ell + 1)^2$
G_2	$115\ell^2 + 71\ell + 11$	$23\ell + 7$	$ 2\ell $	$(10\ell + 3)^2$
H_1	$143\ell^2 + 53\ell + 5$	$11\ell + 2$	$ 2\ell $	$(11\ell + 2)^2$
H_2	$143\ell^2 + 79\ell + 11$	$11\ell + 3$	$ 2\ell $	$(11\ell + 3)^2$
I_1	$168\ell^2 + 32\ell + 1$	$12\ell + 1$	$ 2\ell $	$(12\ell + 1)^2$
I_2	$168\ell^2 + 60\ell + 5$	$12\ell + 2$	$ 2\ell $	$(12\ell + 2)^2$
I_3	$168\ell^2 + 28\ell + 1$	$28\ell + 2$	$ 2\ell $	$(12\ell + 1)^2$
J	$168\ell^2 + 136\ell + 28$	$12\ell + 5$	$ 2\ell + 1 $	$(12\ell + 5)^2$
K	259	15	2	15^2

TABLE 3. $K_{p,k}$ for each (p,k) is a lens space knot in $\Sigma(2,3,7)$ yielding $L(p,k^2)$.

combining the statement above.

Conjecture 1.5. TABLE 2 is a list of all $K_{p,k}$'s in $\Sigma(2,3,5)$ if $2g(K) < p+1$ and TABLE 3 is a list of all $K_{p',k}$'s in $\Sigma(2,3,7)$ if $2g(K) > p'+1$.

We recall estimate $p \leq 2g(K) - 1$ in the cases of lens space surgeries over the non-L-space homology sphere (see Theorem 1.6).

Rasmussen in [11] proved the following:

Theorem 1.6 ([11]). *Let K be a lens space knot in a homology sphere Y . If $2g(K) - 1 < p$ then, Y is an L-space, while if $2g(K) - 1 > p$, then Y is a non-L-space.*

We give families of $K_{p,k}$ in $\Sigma(2,3,6n \pm 1)$ as extension of lens space surgeries in TABLE 2 and 3.

Theorem 1.7. TABLE 4 is a collection of examples of $K_{p,k}$ in $\Sigma(2,3,6n \pm 1)$ for a non-zero integer ℓ . The positive p -surgery of $K_{p,k}$ gives $L(p,k^2)$.

In the same way we state the following conjecture:

Conjecture 1.8. The genus $g(K_{p,k})$ is $(g' + p + 1)/2$, where g' is the value in TABLE 4.

Theorem 1.9. TABLE 5 is a collection of $K_{p,k}$ in $\Sigma(2,2s+1,2(2s+1) \pm 1)$. Here ℓ is a non-zero integer.

Type	p	k	g'
A ₂	$nk^2 \pm (5\ell^2 + 5\ell + 1)$	$5\ell + 2$	$ k(n-1) \pm \ell $
B	$nk^2 \pm (6\ell^2 + 3\ell)$	$6\ell + 1$	$ k(n-1) \pm \ell $
C ₁	$nk^2 \pm (7\ell^2 + 5\ell + 1)$	$7\ell + 2$	$ k(n-1) \pm \ell $
C ₂	$nk^2 \pm (7\ell^2 + 9\ell + 3)$	$7\ell + 4$	$ k(n-1) \pm \ell $
H ₁	$nk^2 \pm (22\ell^2 + 9\ell + 1)$	$11\ell + 2$	$ k(n-1) \pm 2\ell $
H ₂	$nk^2 \pm (22\ell^2 + 13\ell + 2)$	$11\ell + 3$	$ k(n-1) \pm 2\ell $
I ₁	$nk^2 \pm (24\ell^2 + 8\ell)$	$12\ell + 1$	$ k(n-1) \pm 2\ell $
I ₃	$nk^2 \pm (24\ell^2 + 12\ell + 1)$	$12\ell + 2$	$ k(n-1) \pm 2\ell $
J	$nk^2 \pm (24\ell^2 + 16\ell + 3)$	$12\ell + 5$	$ k(n-1) \pm (2\ell + 1) $
K	$nk^2 \pm 34$	15	$ k(n-1) \pm 2 $

TABLE 4. $K_{p,k}$ in $\Sigma(2, 3, 6n \pm 1)$ yielding $L(p, k^2)$.

Type	p	k
A ₂	$\frac{1}{4}(k^2 \mp (k-2)\ell)$	$(4(s+1) \pm 1)\ell + 2$
B ₁	$k^2 \pm (k+2)\ell$	$(4s+2)\ell + 1$
B ₂	$k^2 \pm ((k+2s)\ell + s - 1)$	$(4s+2)\ell + 2s - 1$
D ₁	$\frac{1}{4}(k^2 \mp (3k+2)\ell)$	$(4(3s+1) \pm 3)\ell + 2$
D ₂	$\frac{1}{4}(k^2 \mp (3\ell+2)(k-2))$	$(4(3s+1) \pm 3)\ell + 2(4s+1) \pm 2$
G ₁	$\frac{1}{4}(k^2 \mp (3k+2)\ell)$	$(4(3s+2) \pm 3)\ell + 2$
G ₂	$\frac{1}{4}(k^2 \mp (3\ell+1)(k-2))$	$(4(3s+2) \pm 3)\ell + 2(2s+1) \pm 1$
I ₁	$k^2 \pm (2k\ell + (k-1)/2)$	$4(2s+1)\ell + 2s - 1$
I ₂	$\frac{1}{4}(k^2 \mp 4(k-2)\ell)$	$4(2(2s+1) \pm 1)\ell + 2$
J	$k^2 \pm (2k\ell + (k+1)/2)$	$4(2s+1)\ell + 2s + 3$

TABLE 5. $K_{p,k}$ in $\Sigma(2, 2s+1, 2(2s+1) \pm 1)$ yielding $L(p, k^2)$.

Theorem 1.10. TABLE 6 is a collection of $K_{p,k}$ in $\Sigma(2, 2s+1, 2(2s+1)n \pm 1)$. Here ℓ is a non-zero integer.

Type	p	k
B ₁	$nk^2 \pm (k+2)\ell$	$(4s+2)\ell + 1$
B ₂	$nk^2 \pm ((k+2s)\ell + s - 1)$	$(4s+2)\ell + 2s - 1$
I ₁	$nk^2 \pm (2k\ell + (k-1)/2)$	$4(2s+1)\ell + 2s - 1$
J	$nk^2 \pm (2k\ell + (k+1)/2)$	$4(2s+1)\ell + 2s + 3$

TABLE 6. $K_{p,k}$ in $\Sigma(2, 2s+1, 2(2s+1)n \pm 1)$ yielding $L(p, k^2)$.

To obtain these tables, we will look back $K_{p,k}$'s in TABLE 2 and give the knot diagrams of them (Appendix 1, 2). By using these diagrams, we give straight extensions of $K_{p,k}$ to Brieskorn homology spheres, $\Sigma(2, 3, 6n \pm 1)$, $\Sigma(2, 2s+1, 2(2s+1) \pm 1)$ and $\Sigma(2, 2s+1, 2(2s+1)n \pm 1)$. For lens surgeries of other types of Brieskorn homology spheres, see Section 4.1.1 to 4.1.6. For examples, Brieskorn homology spheres

$$\Sigma(m, ms + m - 1, m(ms + m - 1)n \pm 1),$$

for positive integers s, n, m admit similar quadratic families of lens space surgeries.

Theorem 1.11. Suppose on data of TABLE 7 we impose the restriction that r_1, s_1, t_1 are pairwise relatively prime in addition to the condition indicated in the table. The

Seifert data in TABLE 7 present Brieskorn homology spheres $\Sigma(|r_1|, |s_1|, |t_1|)$ (up to orientation) containing $K_{p,k}$.

Type	$S(e, (r_1, r_2), (s_1, s_2), (t_1, t_2))$	Condition
A	$S(1, (2, 1), (2s + 1, 1), *)$	$s \in \mathbb{Z}_{>0}$
B	$S(1, (2a - 1, a), *, *)$	$a \in \mathbb{Z} \setminus \{0\}$
CD	$S(1, (m, m - 1), (\beta, 1), *)$	$m \in \mathbb{Z} \setminus \{1\}, \beta \in \mathbb{Z}_{>0}$
E	$S(1, (2m - 1, m - 1), (\alpha, 1), (\beta, 1))$	$m \in \mathbb{Z} \setminus \{1\}, \alpha, \beta \in \mathbb{Z}_{>0}$
FGH	$S(1, (a, 1), (b, 1), *)$	$a, b \in \mathbb{Z}_{>0}$
I	$S(1, (c, 1), *, *)$	$c \in \mathbb{Z}_{>0}$
J	$S(1, (2, 1), *, *)$	
K	$S(1, (3, 1), (m, m - 1), *)$	$m \in \mathbb{Z} \setminus \{1\}$

TABLE 7. The Seifert data (up to orientation) of Brieskorn homology spheres containing $K_{p,k}$, where * means any multiplicity.

The data in TABLE 7 do not give all the Brieskorn homology spheres. For example, $\Sigma(7, 11, 15)$ has the Seifert data $S(1, (7, 2), (11, 2), (15, 8))$. Hence, it is not determined whether $\Sigma(7, 11, 15)$ contains $K_{p,k}$ or generally any lens space knot or not. On the other hand, we would like to address the following conjecture.

Conjecture 1.12. *Any Brieskorn homology sphere contains $K_{p,k}$.*

As an analog of the result in [15], we conjecture the following. This conjecture can be checked for our examples appeared in this paper.

Conjecture 1.13. *Any Brieskorn homology sphere $-\Sigma(p, q, r)$ with the orientation opposite to the usual one does not contain $K_{p,k}$.*

In the case of $(p, q, r) = (2, 3, 5)$, there is no positive lens space knots in $-\Sigma(2, 3, 5)$, as proven in [15].

The final result of this paper is to give families of double-primitive knots in some graph homology spheres. Here we denote the graph manifold with the plumbing diagram as in FIGURE 1 by $G(\{A, B\}, \{C, D\}; a, b)$ for four rationals A, B, C, D and two integers a, b . We refer [13] for the plumbing diagram for plumbed 3-manifold.

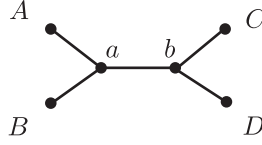

FIGURE 1. The plumbing graph for $G(\{A, B\}, \{C, D\}; a, b)$

Theorem 1.14. *Suppose that graph homology spheres of the form above have the following condition:*

- (1) $G(\{2, 3\}, \{P/Q, m/(m-1)\}; 0, 0)$ where m is any integer, P, Q, m satisfy $-5P + 5mQ - Pm = \pm 1$.
- (2) $G(\{2, 5\}, \{P/Q, m/(m-1)\}; 0, 0)$ where m is any integer, P, Q, m satisfy $-7P + 7mQ - 3mP = \pm 1$.

Then the homology spheres contain $K_{p,k}$ and produce the lens space $L(p, q)$ with

$$p/q = [\alpha_n, \dots, \alpha_1, \ell + 1, 2, -m, 3, -\ell],$$

$$p/q = [\alpha_n, \dots, \alpha_1, \ell + 1, 2, -m, 5, -\ell],$$

where $[\alpha_1, \alpha_2, \dots, \alpha_n] = P/Q$ is satisfied.

There is a natural question here: Are there any hyperbolic homology sphere $Y_{p,k}$? In this article, we deal with non-hyperbolic $Y_{p,k}$ only. In the forthcoming article we will give examples of hyperbolic $Y_{p,k}$.

1.3. Application to the $b_2 = 1$ 4-manifold with lens space boundary. The computation of this article is definitely useful to construct simply connected 4-manifolds with small b_2 whose boundaries are lens spaces. ‘Small’ means $b_2 = 1$ here. If a lens space is constructed by integral Dehn surgery of S^3 , then the lens space is the boundary of a 4-manifold with $b_2 = 1$. Our several lists in this article may give interesting small b_2 bounds of lens spaces even if the lens spaces are not Dehn surgeries of knots in S^3 . Namely, the 4-manifolds are simply connected and homologically S^2 but never admit exact two Morse critical points. The strategy is to give lens space surgeries over homology spheres which bound contractible 4-manifolds. The reason for the lens space not to bound a 4-manifold with exact two Morse critical points is by the work of Greene in [5]. For example, such Brieskorn homology spheres are $\Sigma(2, 5, 7)$, $\Sigma(2, 3, 13)$ or $\Sigma(3, 4, 5)$ etc. See [2].

As mentioned at Section 1.6 in [5], $L(17, 15)$ cannot bound a 4-manifold with index 0 and 2. However the lens space bounds a 4-manifold with $b_2 = 1$. Here, we give families of lens spaces (including $L(17, 15)$) which bound 4-manifold with $b_2 = 1$. Lens space surgeries over $\Sigma(2, 3, 13)$ can be already viewed in Theorem 1.7 by taking $n = 2$ and plus sign.

Proposition 1.15. *For any non-zero integer ℓ , there are quadratic families of lens space surgeries on $\Sigma(2, 5, 7)$ as follows:*

$$L(35\ell^2 + 21\ell + 3, (7\ell + 2)^2) \quad (\text{A type surgeries})$$

$$L(117\ell^2 + 37\ell + 3, (13\ell + 2)^2) \quad (\text{C}_1\text{D}_1 \text{ type surgeries})$$

$$L(117\ell^2 + 145\ell + 45, (13\ell + 8)^2) \quad (\text{C}_2\text{D}_2 \text{ type surgeries})$$

For any non-zero integer ℓ , there are quadratic families of lens space surgeries on $\Sigma(3, 4, 5)$ as follows:

$$L(86\ell^2 + 37\ell + 4, (43\ell + 9)^2) \quad (\text{E type surgeries})$$

$$L(86\ell^2 + 49\ell + 7, (43\ell + 12)^2) \quad (\text{E type surgeries})$$

In particular, $L(17, 15)$ is given by an A type 17-surgery in $\Sigma(2, 5, 7)$ in TABLE 7. In fact, this knot K is isotopic to $K_{17,7}$. C_1D_1 type or C_2D_2 type will be explained in Section 4.1.3.

This proposition implies the existence of sufficiently many families of lens spaces which bound simply connected 4-manifolds with $b_2 = 1$ but do not have exact two Morse critical points. On the other hand $L(17, 2)$ (the orientation reversing $L(17, 15)$) appears in A_2 type ($n = 2$, minus sign, and $\ell = -1$) in TABLE 4. $L(17, 2)$ is the 17-surgery of a lens space knot in $\Sigma(2, 3, 11)$. Read [5].

In this way, easily the reader would be able to find lens spaces bounding 4-manifolds $b_2 = 1$.

2. PRELIMINARY

2.1. Simple (1,1)-knot. Let p be a positive integer. Let \tilde{K} be a knot in $L(p, q)$ that is a generator in $H_1(L(p, q))$. Let m be the meridian of \tilde{K} . The m lies on $\partial L(p, q)_0$, where $L(p, q)_0$ is the exterior of \tilde{K} . We choose a longitude l of \tilde{K} . The pair $([m], [l])$ produces an oriented basis on $H_1(\partial L(p, q)_0)$. Since $H_1(L(p, q)) \cong \mathbb{Z}/p\mathbb{Z}$, $a[m] + p[l]$ is null-homologous in $H_1(L(p, q)_0)$ for some integer a . Namely, $H_1(L(p, q)_0) = \langle [m], [l] \rangle / a[m] + p[l] \cong \mathbb{Z}$ holds. The number $a \bmod p$ is the invariant of \tilde{K} because another choice of l changes a to $a + np$ for some integer n . The number

a modulo p is called a *self-linking number*. The computation of the linking form $\ell k : H_1 \times H_1 \rightarrow \mathbb{Q}/\mathbb{Z}$ gives $\ell k([\tilde{K}], [\tilde{K}]) = (a[m] + p[l]) \cdot [l]/p = a/p \pmod{1}$.

If \tilde{K} is a generator is a generators in $H_1(L(p, q))$, $L(p, q)_0$ is homeomorphic to the exterior of a knot in a homology sphere. Suppose that the integral b -surgery produces a homology sphere Y with the dual knot K . Then $a[m] + p[l]$ represents a longitude of K and $b[m] + [l]$ is a meridian of K . For $\epsilon = \pm 1$, if $(\epsilon(b[m] + [l]), a[m] + p[l])$ is the oriented basis with the same orientation as $([m], [l])$, then $\epsilon(bp - a) = 1$ holds. The Dehn surgery of K produces $L(p, q)$.

Lemma 2.1. *If the positive p -surgery $Y_p(K)$ is homeomorphic to $L(p, q)$, then $a \equiv 1 \pmod{p}$.*

Proof. Since $p\epsilon(b[m] + [l]) + a[m] + p[l]$ must be homologous to $\pm[m]$, $\epsilon = -1$ holds. Thus $a = bp - \epsilon \equiv 1 \pmod{p}$ holds. \square

As a result we have the following corollary:

Corollary 2.2. *For a longitude l of a homologically generating knot $\tilde{K} \subset L(p, q)$, there exists an integer b uniquely such that b -surgery of \tilde{K} is a homology sphere.*

Proof. If the integral b -surgery of \tilde{K} with respect to l is a homology sphere, then $pb + 1 = a$, where the $a[m] + p[l]$ is null-homologous in $H_1(L(p, q)_0)$. Thus b is uniquely determined. \square

Here we give a corollary.

Corollary 2.3. *Let p be a positive integer. If $L(p, q) = Y_p(K)$ with dual class k and with a homology sphere Y , then $k^2 = q \pmod{p}$.*

Proof. Suppose that \tilde{K} is the dual knot of the lens space surgery with $[\tilde{K}] = k[c]$ for the core circle c in V_1 of genus one Heegaard decomposition $V_0 \cup V_1$ of $L(p, q)$, where V_1 is the neighborhood of the dual knot of $S_{p/q}^3(\text{unknot})$. Thus comparing the linking form $1/p = \ell k(k[c], k[c]) = k^2 \cdot \ell k([c], [c]) = k^2 q'/p \pmod{p}$, where the self-linking number of $[c]$ is q' , where q' is the inverse of q in $(\mathbb{Z}/p\mathbb{Z})^\times$. Thus $q = k^2 \pmod{p}$ holds. \square

Here we give definitions of (1,1)-knot and simple (1,1)-knot.

Definition 2.1 ((1,1)-knot in a 3-manifold). Let L be a 3-manifold with Heegaard genus at most 1. Let $V_0 \cup V_1$ be a genus 1 Heegaard splitting of L . We say that a knot K' in L is a (1,1)-knot if K' is isotopic to K satisfying the following conditions:

- (1) (transversality condition) K transversely intersects with the Heegaard surface $\partial V_0 = \partial V_1$.
- (2) (∂ -parallel condition) $K_i = V_i \cap K$ is a proper-embedded *boundary-parallel* arc in V_i , i.e., there exists an embedded disk D_i in V_i with $\partial D_i = K_i \cup \alpha_i$ where α_i is a simple arc in ∂V_i .

We call such a position of the knot K in L *(1,1)-position*. The (1,1) means that the manifold has a genus one Heegaard decomposition and the knot is 1-bridge.

Furthermore, we define a *simple* (1,1)-knot.

Definition 2.2 (Simple (1,1)-knot $\tilde{K}_{p,q,k}$ in $L(p, q)$). Let K be a (1,1)-knot in the genus 1 Heegaard splitting $V_0 \cup V_1$ of lens space $L(p, q)$. Let D_i be the meridional disk of V_i . Let α, β be ∂D_0 and the image of ∂D_1 on ∂V_0 respectively (FIGURE 2). We assume that α and β are minimally intersecting. Then if K is isotopic to the union of the two arcs each of which is embedded in D_i , we call such a knot K a *simple (1,1)-knot* in $L(p, q)$. The embedded arc K_0 in V_0 is described as in FIGURE 2.

Note that non-simple (1,1)-knot cannot be *simultaneously* embedded in the meridional disks of the genus one Heegaard decomposition.

As in FIGURE 2, the minimal intersection $\alpha \cap \beta$ consists of p points. We name the points as $\{0, 1, \dots, p-1\}$ in order. Suppose that the arc K_0 of simple (1,1)-knot in V_0 is connecting the points 0 and k in the meridian disk. Then we denote such a simple (1,1)-knot by $\tilde{K}_{p,q,k}$.

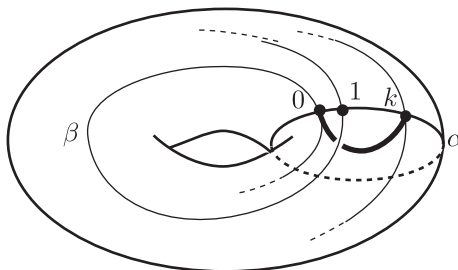

FIGURE 2. A simple (1,1)-knot K_0 in V_0 .

By the definition of simple (1,1)-knot, $\tilde{K}_{p,q,k}$ is isotopic to $\tilde{K}_{p,q,-k}$. We denote $\tilde{K}_{p,k^2,k}$ by $\tilde{K}_{p,k}$ and the integral \mathbb{Z} HS surgery of $\tilde{K}_{p,k}$ by $Y_{p,k}$. We denote the dual knot of the surgery by $K_{p,k} \subset Y_{p,k}$. Hence, we can write the surgery as $(Y_{p,k})_p(K_{p,k}) = L(p, k^2)$.

By exchanging the role of the solid tori, the dual class k is changed as $k \mapsto \pm k^{-1}$ in $(\mathbb{Z}/p\mathbb{Z})^\times$. Hence, we have the ambiguity $\mathcal{K} := \{\pm k^{\pm 1}\} \subset \{0, 1, \dots, p-1\}$ as a set of the smallest positive remainders. We choose k as the minimal element in \mathcal{K} and k_2 is the second minimal one with $kk_2 = \pm 1 \pmod{p}$ (possibly $k = k_2$). Throughout the paper we define \mathfrak{c} to be $(k-1)(k+1-p)/2$.

2.2. Brieskorn homology spheres. Brieskorn sphere $\Sigma(a_1, a_2, a_3)$ is defined to be $\{(z_1, z_2, z_3) \in \mathbb{C}^3 \mid z_1^{a_1} + z_2^{a_2} + z_3^{a_3} = 0\} \cap S^5$. $\Sigma(a_1, a_2, a_3)$ is a Seifert 3-manifold with S^2 base space with three multiple fibers. The general properties of Seifert manifolds lie in [10]. The Seifert manifold is presented by *multiplicity* (a, b) for the multiple fiber *Euler number* e , where the numbers (a, b) are coprime integers. Hence, the Brieskorn homology sphere $\Sigma(a_1, a_2, a_3)$ is presented as follows:

$$S(e, (a_1, b_1), (a_2, b_2), (a_3, b_3)).$$

We call the presentation *Seifert data*. If the Brieskorn sphere $\Sigma(a_1, a_2, a_3)$ is a homology sphere, then integers (a_1, a_2, a_3) are pairwise relatively prime. The presentation satisfies with

$$e - \sum_{i=1}^3 \frac{b_i}{a_i} = \frac{\pm 1}{a_1 a_2 a_3}$$

and is described by Kirby diagram as in FIGURE 3. For example, $\Sigma(2, 2s+1, 2(2s+1)n \pm 1)$ admits the following Seifert data:

$$\mp S(1, (2, 1), (2s+1, s), (2(2s+1)n \pm 1, n)).$$

3. KNOT DIAGRAMS OF $\tilde{K}_{p,k}$ AND $K_{p,k}$.

The purpose of this section is to give a process to obtain knot diagrams of $\tilde{K}_{p,k}$ and $K_{p,k}$.

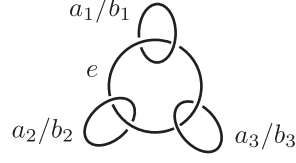

FIGURE 3. Kirby diagram of $\Sigma(a_1, a_2, a_3)$ with Seifert data $S(e, (a_1, b_1), (a_2, b_2), (a_3, b_3))$.

3.1. Involution on $L(p, k^2)$ and $\tilde{K}_{p,k}$. To describe $\tilde{K}_{p,k}$ in a lens space $L(p, k^2)$, we use the involution ι on $L(p, q)$. It is well-known that any lens space is a double branched cover along a 2-bridge knot or link in S^3 . Consider the genus 1 Heegaard splitting of a lens space $V_0 \cup V_1$. The Heegaard surface $T = \partial V_0 = \partial V_1$ is an invariant set i.e., $\iota(T) = T$. The restriction of the involution ι to T is the same thing as the -1 -multiplication on $\mathbb{C}/(\mathbb{Z} + i\mathbb{Z})$ (topologically 180° -rotation as in FIGURE 4). We set $\bar{V}_i = V_i/\iota$. Each \bar{V}_i is homeomorphic to a 3-ball. The set γ_i is the image of the fixed points set $\text{Fix}(V_i, \iota)$ in \bar{V}_i , which are two properly embedded arcs (the red dashed lines in FIGURE 4). We call such a 3-ball \bar{V}_0 *pillowcase*. The boundary points $\partial\gamma_i$ are four points and we call the points *vertices* of the pillowcase. As a result, the quotient $L(p, q)/\iota$ gives a genus 0 Heegaard splitting $\bar{V}_0 \cup_{S^2} \bar{V}_1$ of S^3 . We set the gluing map as $g_{p,q} : \partial\bar{V}_1 \rightarrow \partial\bar{V}_0$. The map is isotopic to the identity map as a homeomorphism on S^2 .

We consider \bar{V}_0 . We denote the positions of the images of two parallel meridians α_0, α_1 and two parallel longitudes l_0, l_1 in V_0 by $\bar{\alpha}_0$ (top), $\bar{\alpha}_1$ (bottom), \bar{l}_0 (left), \bar{l}_1 (right), which are four arcs. The union of the four arcs makes a *rectangle* R on $\partial\bar{V}_0$ as the first row in FIGURE 4. The four vertices of R are the vertices of the pillowcase. The $\bar{l}_i, \bar{\alpha}_i$ and R are used as ‘coordinate’ of pillowcase. We can also see a similar picture in \bar{V}_1 . We denote the images of two parallel meridians β_0, β_1 in V_1 as in FIGURE 4 by $\bar{\beta}_0, \bar{\beta}_1$.

Let K be a simple (1,1)-knot $\tilde{K}_{p,q,k}$. Let K_i be the same thing as that in Definition 2.1. The K_i may be chosen to be an invariant arc as indicated in the left of above two pictures in FIGURE 4. Then, each arc K_i is an invariant set with respect to ι . Let K'_i be the image of K_i in \bar{V}_i . Then K'_0 (or K'_1) is an arc connecting a point in γ_0 (or γ_1) and a point of $\bar{\alpha}_0$ (or $\bar{\beta}_0$). We determine the point $\bar{\alpha}_0 \cap \partial K'_0$. The image of $\bar{\beta}_0 \cup \bar{\beta}_1$ by the gluing map $g_{p,q}$ is two lines in $\partial\bar{V}_0$ with slope p/q as in FIGURE 5. We call $g_{p,q}(\bar{\beta}_0 \cup \bar{\beta}_1) \subset \partial\bar{V}_0$ *pillowcase slope*. If $p/q > 0$ then the pillowcase slope is called *positive* and if $p/q < 0$ then *negative*. The inclined lines in FIGURE 5 stand for pillowcase slope in $\partial\bar{V}_0$. On the $\bar{\alpha}_i$ there are $p+1$ intersection points with $g_{p,q}(\bar{\beta}_0 \cup \bar{\beta}_1)$. In the same way we put $q+1$ points on $\bar{l}_i \subset \partial\bar{V}_0$. These $2(p+q)$ points on the rectangle are called *integral points*. The points are named $0, 1, \dots, p$ on $\bar{\alpha}_i$ from the left in order and $0, 1, \dots, q$ on \bar{l}_i from the top in order and we call this scale of the rectangle *measure*. As an example of measure see the third row of FIGURE 4. The boundary points of K'_0 are $k \in \bar{\alpha}_0$ and a point in γ_0 .

3.2. Pillowcase method. It is the main purpose in this section that by deforming the gluing map $g_{p,q}$ of two pillowcases into the identity map, we keep track of the image of the simple (1,1)-knot in \bar{V}_0 . We call the following process *pillowcase method* here. For coprime integers P, Q we consider a triple $(P/Q, \gamma, K')$ in the pillowcase \bar{V} , where \bar{V} is a pillowcase \bar{V}_0 with rectangle R . The rectangle R is the same meaning as the previous section. The pillowcase slope is P/Q , and γ is a 2-component tangle whose end points are the four vertices in $\partial\bar{V}$. $\text{Int}(K') \subset \bar{V} \setminus \gamma$ is an edge connecting a point in R and a point in γ . Here Int means the interior. If

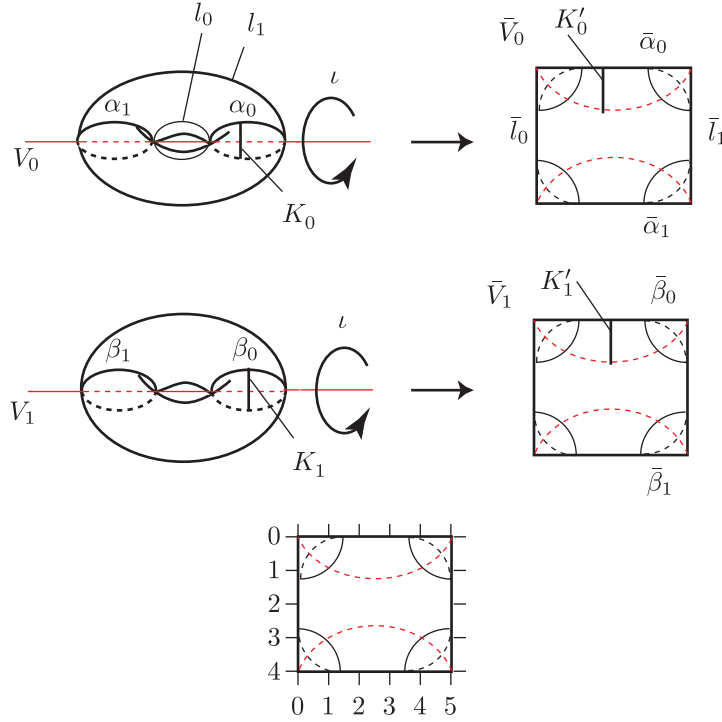

FIGURE 4. The involution of a lens space and a branched locus of S^3 . The red curves are fixed point sets, an example of the measure of the pillowcase with slope $p/q = \pm 5/4$

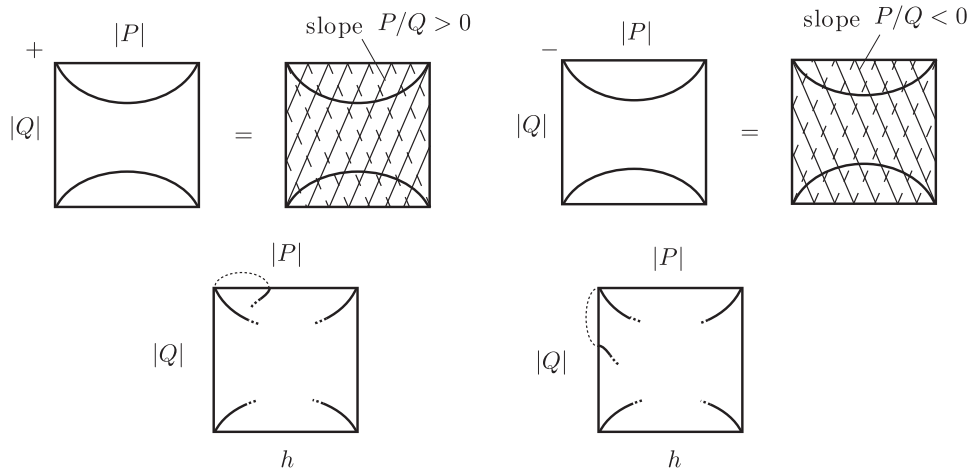

FIGURE 5. The notation of pillow case description

the slope is positive, negative, 0 or ∞ , we write $+$, $-$, 0 or ∞ respectively on the left top of R , as in FIGURE 5. If the integral point of $K' \cap R$ is h , then we write the number under the pillowcase. When the K does not intersect with R , we write no number any more there. The second row of FIGURE 5 describes a part of γ and K' . The intersection $K' \cap R$ is an integral point h in the measure of $\bar{\alpha}_0 \cup \bar{l}_0 \subset R$. Such a triple is called *pillowcase triple*.

Now we suppose pillowcase triple $(P/Q, \gamma, K')$ satisfies $|P| > |Q|$ and the one end point $K' \cap R$ is an integral point in $\bar{\alpha}_0$, i.e., it is in $\{0, 1, 2, \dots, p\}$. The picture is either of the top pictures in FIGURE 6 or 7 depending on the sign of P/Q . The black boxes stand for some tangles of γ and K' . We divide h by Q as follows:

$$h = bQ - h'.$$

Here b, h' are some integers. Untwisting the end point $h \in \bar{\alpha}_0$ along the slope P/Q , we get the one pattern of four cases as in FIGURE 6 or 7. Here if necessary, we turn the pillowcase by 180° so that the end point $K' \cap R$ can be moved to $|h'| \in \bar{l}_0$.

We suppose the pillowcase triple satisfies $|P| < |Q|$. The one end point $K' \cap R$ is an integral point in \bar{l}_0 as in FIGURE 8 or 9. In the same way as the case of $|P| > |Q|$, we divide h by P as follows:

$$h = bP - h'.$$

Here b, h' are some integers. We untwist the arc K' along the slope on $\partial\bar{V}$ so that the boundary of $K' \cap R$ lies in $\bar{\alpha}_0 \cup \bar{\alpha}_1$. Similarly, if necessary, we turn the pillowcase by 180° so that the end point $K' \cap R$ is an integral point in $\bar{\alpha}_0$. The pattern is one of four in FIGURE 8 or 9. These processes are called *untwisting process of K'* . As a result, by untwisting process of K' , for the pillowcase triple $(P/Q, \gamma, K')$ with $P/Q \neq 0$ and ∞ , $K' \cap R \in \bar{l}_0$ if $|P/Q| > 1$ or $K' \cap R \in \bar{\alpha}_0$ if $|P/Q| < 1$.

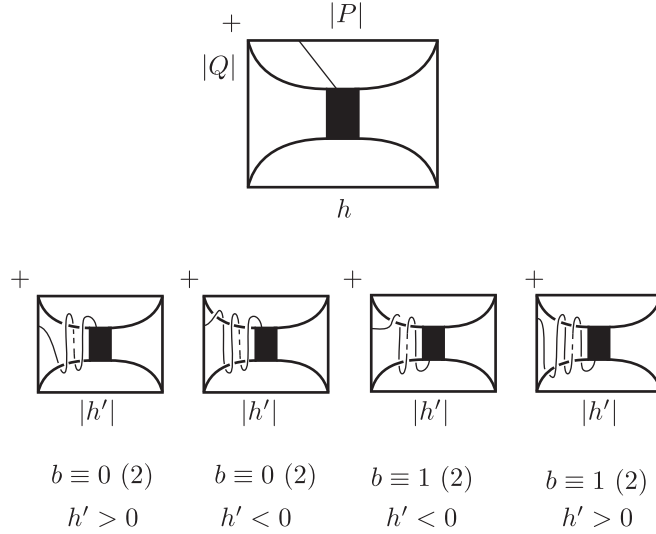

FIGURE 6. The positive slope pillowcase in the case of $|P/Q| > 1$ and the untwisting by $h = bQ - h'$.

Next, we untwist the pillowcase. We suppose that $|P/Q| > 1$ and $P/Q \neq \infty$. See FIGURE 10. Divide P by Q and we get $P = aQ - P'$, where a and P' are some integers. Here we untwist the pillowcase in \bar{V} by half $|a|$ -times along the central horizontal line of \bar{V} in the $\text{sgn}(-P/Q)$ direction. Hence, the new pillowcase slope becomes $-P'/Q$ (the bottom pictures in FIGURE 10). The box with an integer stands for the half twist by the number.

For the assumption $|P/Q| < 1$, we untwist the pillowcase similarly. Divide Q by P and we get $Q = aP - P'$, where a, P' are some integers. Then we deform the pillowcase as the second row in FIGURE 11 according to the sign of $-P/P'$. These pictures are the cases of $P/Q > 0$. In the case of $P/Q < 0$, we can also describe a similar picture.

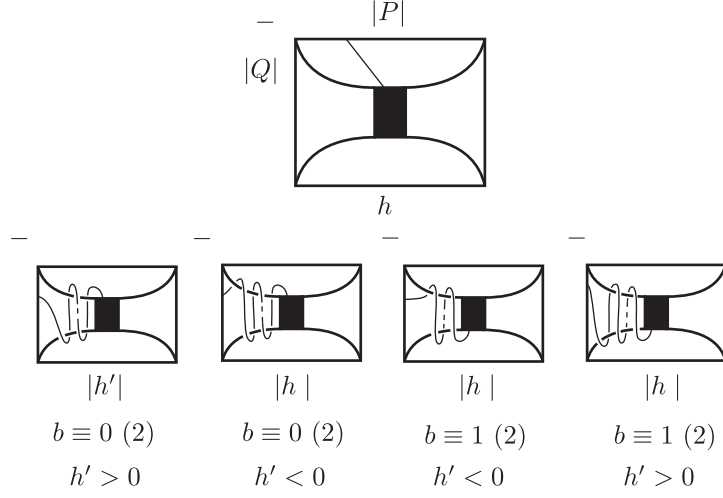

FIGURE 7. The negative slope pillowcase in the case of $|P/Q| > 1$ and the untwisting by $h = bQ - h'$.

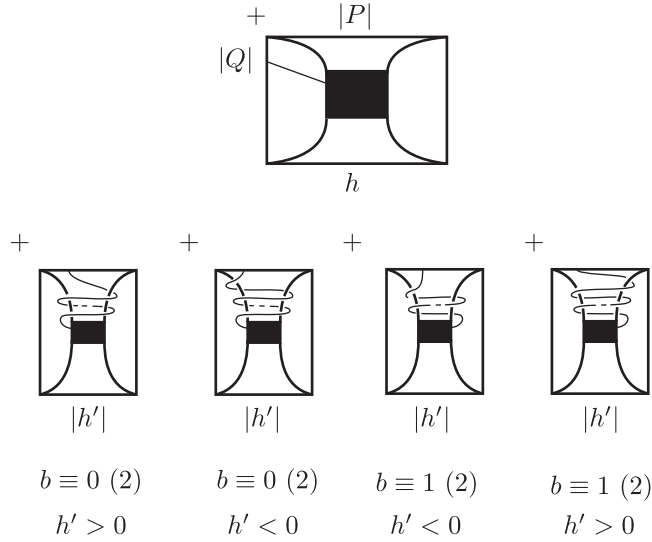

FIGURE 8. The positive slope pillowcase in the case of $|P/Q| < 1$ and untwisting by $h = bP - h'$.

We iterate the untwisting process of \bar{V} or K' alternatively,

$$(p/q, \gamma, K') \rightarrow (p/q, \gamma, K'') \rightarrow (p/p', \gamma', K'') \rightarrow (p/p', \gamma', K''') \rightarrow \dots$$

After several untwisting processes, we obtain $P/Q = 0$ or $P/Q = \infty$. Then via the gluing map, we can push the other 2-component arcs K'_1 in \bar{V} and gluing \bar{V}_1 , we get a 2-bridge knot or link attaching an arc in S^3 .

Expand the continued fraction of p/q where $p = p_1, q = p_2$ as follows:

$$p_i = a_i p_{i+1} - p_{i+2} \quad (i = 1, \dots, n-1),$$

and

$$p_n = a_n p_{n+1}, |p_{n+1}| = 1.$$

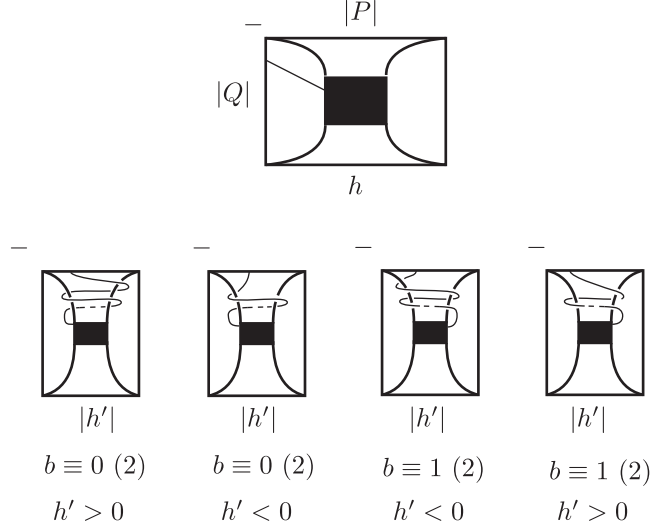

FIGURE 9. The negative slope pillowcase in the case of $|P/Q| < 1$ and untwisting by $h = bP - h'$.

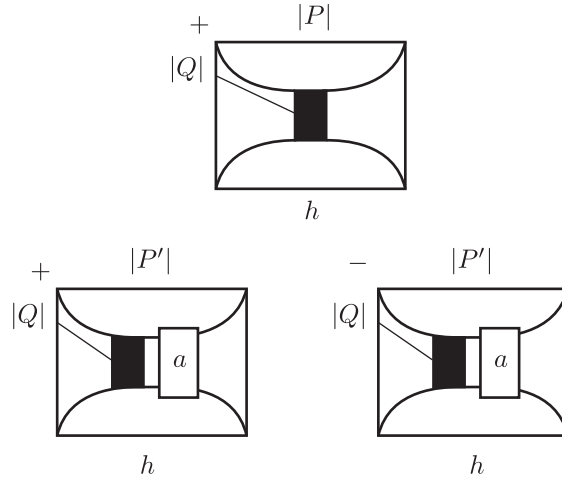

FIGURE 10. Untwisting the pillowcase with $|P/Q| > 1$.

Such a sequence p_1, p_2, \dots, p_{n+1} is not uniquely determined from p/q , while the existence is guaranteed by the Euclidean algorithm. Thus, an iteration of untwisting processes can deform any triple $(p/q, \gamma, K')$ into a triple with slope $1/0$ or $0/1$.

Namely, we obtain the continued fraction

$$p/p_2 = [a_1, a_2, \dots, a_n] = a_1 - \frac{1}{a_2 - \frac{1}{a_3 - \dots - \frac{1}{a_n}}}.$$

Here we denote $\epsilon_i = (-1)^{i-1} \text{sign}(a_i)$. Each ϵ_i corresponds to the signature of the pillowcase slope.

Here we consider the sequences b_1, b_2, \dots, b_n and $k = h_1, h_2, \dots, h_n$ defined as follows:

$$k = b_1 p_2 - h_2, h_i = b_i p_{i+1} - h_{i+1}, h_n = b_n p_{n+1}.$$

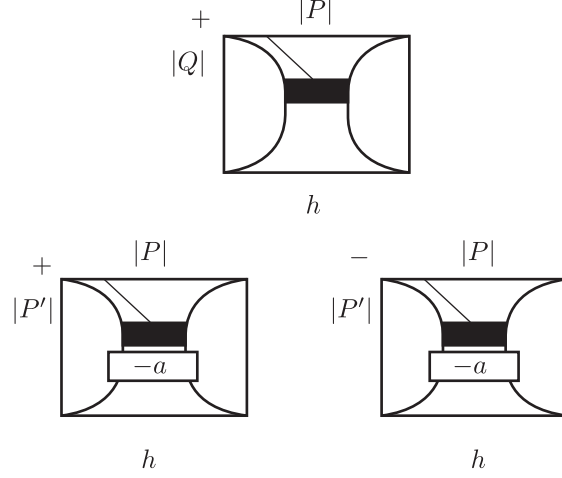
 FIGURE 11. Untwisting the pillowcase with $|P/Q| < 1$.

Hence, we have $k = \sum_{i=1}^n b_i(-1)^{i-1}p_{i+1}$. For the lens surgery parameter (p, k) we call (a_1, \dots, a_n) its a -sequence, (b_1, \dots, b_n) its b -sequence, and (h_1, \dots, h_n) its h -sequence. In TABLE 8 and 9, we give the a -sequences (of continued fractions of p/q), and b -sequences for lens surgeries in TABLE 2:

$$\Sigma(2, 3, 5)_p(K_{p,k}) = L(p, q).$$

The p, q in TABLE 8 correspond to p_1 and p_2 for the continued fraction of p/q . Note that the b -sequence for $\Sigma(2, 3, 7)$ is the one of b -sequence with the type multiplied by -1 as a vector.

Example: An example $S_5^3(\text{trefoil}) = L(5, 2^2)$: pillowcase, untwisting of pillowcase or K' , Kirby calculus. Here we give an example $S_5^3(\text{trefoil}) = L(5, 2^2)$. This example is well-known as the first non-trivial lens space surgery in S^3 . The continued fraction is

$$5/4 = 1 - 1/(-4) = [1, -4].$$

The pillowcase method is (1)-(5) in FIGURE 12. We give the simple (1,1)-knot $\tilde{K}_{5,2}$ in (6)-(7). The diagram of $K_{5,2} \subset S^3$ is given in (8)-(9). We explain each process in detail.

First, we give a simple (1,1)-knot in $L(5, 2^2)$ with dual class 2 in the pillowcase: (1) in FIGURE 12. The red curves in FIGURE 12 are γ . We untwist K' as the deformation from (1) to (2) in FIGURE 12. We untwist the pillowcase (from the (2) to (3)). From (3) we obtain (5) by untwisting pillowcase and K' in the similar way. Pushing K'_1 in \bar{V} , we obtain (6). The double branched cover along the 2-bridge knot is (7). The good reference from (6) to (7) is [9]. This diagram presents $Y_{5,2^2} = S^3$. The -1 -framed component in (7) is $\tilde{K}_{5,2}$. The 0-framed meridian $\tilde{K}_{5,2}$ in (8) is the trefoil with $+5$ -framing as in (9) by trivializing the diagram other than 0-framed meridian.

3.3. $K_{p,k}$ in $\Sigma(2, 3, 5)$. In this section we concretely give knot diagrams of $\tilde{K}_{p,k}$ and $K_{p,k}$ for (p, k) given in TABLE 2 according to the pillowcase method (untwisting pillowcase and K') which is explained in the previous subsection. The simple but concrete example is already illustrated in FIGURE 12. Here we carry out the positive ℓ cases only. The descriptions of negative ℓ cases are similar. The difference is the direction of the untwisting, hence we omit them.

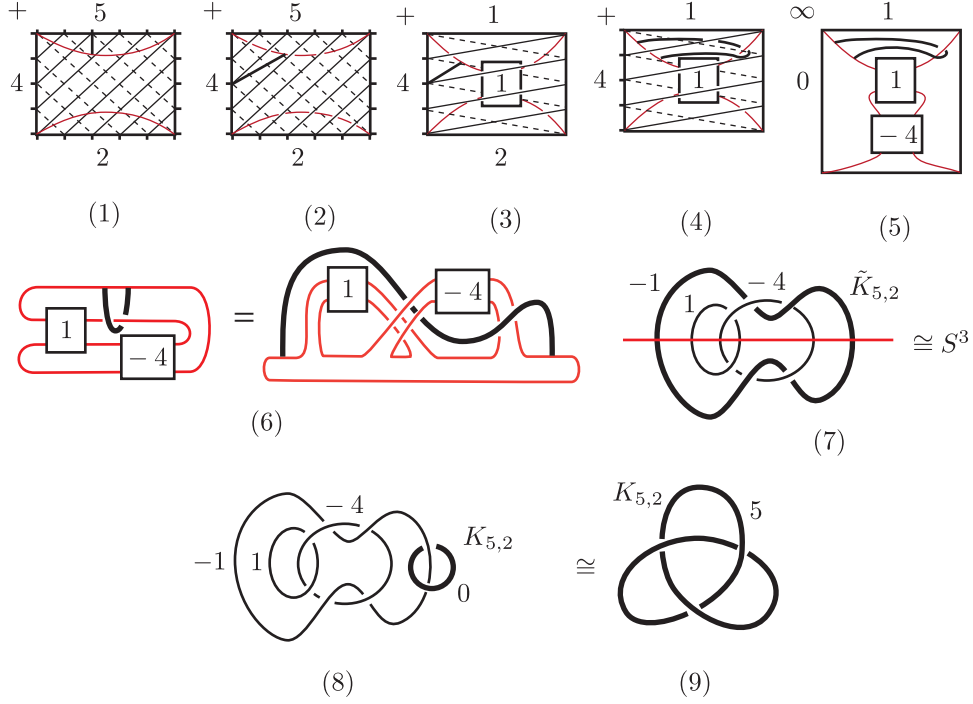

FIGURE 12. Example: The pillowcase method for $(5/4, \gamma, K')$, the double covering along the 2-bridge knot or link (red curve), and the knot diagram of $K_{5,2}$ in S^3 .

type	p	q	a -sequence
A ₁	$14\ell^2 + 7\ell + 1$	$7\ell^2 + 7\ell + 1$	$[2, \ell + 1, 7, -\ell]$
A ₂	$20\ell^2 + 15\ell + 3$	$5\ell^2 + 5\ell + 1$	$[4, \ell + 1, 5, -\ell]$
B	$30\ell^2 + 9\ell + 1$	$6\ell^2 + 3\ell$	$[5, \ell + 1, 3, -\ell + 1, 2]$
C ₁	$42\ell^2 + 23\ell + 3$	$7\ell^2 + 5\ell + 1$	$[6, \ell, -3, 2, -\ell]$
C ₂	$42\ell^2 + 47\ell + 13$	$7\ell^2 + 9\ell + 3$	$[6, \ell + 1, 2, -3, -\ell - 1]$
D ₁	$52\ell^2 + 15\ell + 1$	$13\ell^2 + 7\ell + 1$	$[4, \ell, -3, 4, -\ell]$
D ₂	$52\ell^2 + 63\ell + 19$	$13\ell^2 + 19\ell + 7$	$[4, \ell + 1, 4, -3, -\ell - 1]$
E ₁	$54\ell^2 + 15\ell + 1$	$27\ell^2 + 21\ell + 3$	$[2, \ell + 1, 3, 2, 6, -\ell]$
E ₂	$54\ell^2 + 39\ell + 7$	$27\ell^2 + 33\ell + 9$	$[2, \ell + 1, 6, 2, 3, -\ell]$
F ₁	$69\ell^2 + 17\ell + 1$	$46\ell^2 + 19\ell + 2$	$[2, 2, \ell + 1, 4, 6, -\ell]$
F ₂	$69\ell^2 + 29\ell + 3$	$46\ell^2 + 27\ell + 4$	$[2, 2, \ell + 1, 6, 4, -\ell]$
G ₁	$85\ell^2 + 19\ell + 1$	$34\ell^2 + 11\ell + 1$	$[3, 2, \ell + 1, 3, 6, -\ell]$
G ₂	$85\ell^2 + 49\ell + 7$	$34\ell^2 + 23\ell + 4$	$[3, 2, \ell + 1, 6, 3, -\ell]$
H ₁	$99\ell^2 + 35\ell + 3$	$22\ell^2 + 9\ell + 1$	$[5, 2, \ell + 1, 3, 4, -\ell]$
H ₂	$99\ell^2 + 53\ell + 7$	$22\ell^2 + 13\ell + 2$	$[5, 2, \ell + 1, 4, 3, -\ell]$
I ₁	$120\ell^2 + 16\ell + 1$	$24\ell^2 + 8\ell$	$[5, \ell + 1, 2, 3, 2, -\ell + 1, 3]$
I ₂	$120\ell^2 + 20\ell + 1$	$40\ell^2 + 20\ell + 1$	$[3, \ell + 1, 2, 6, 2, -\ell + 1, 2]$
I ₃	$120\ell^2 + 36\ell + 3$	$24\ell^2 + 12\ell + 1$	$[5, \ell + 1, 2, 4, 2, -\ell + 1, 2]$
J	$120\ell^2 + 104\ell + 22$	$24\ell^2 + 16\ell + 3$	$[5, -\ell - 1, -2, -3, -2, \ell, 3]$
K	191	34	$[6, 2, -2, -3, -3]$

TABLE 8. Table of continued fractions of p/q for $L(p, q)$ in FIGURE 2.

type	$(p_3, \dots, p_n, p_{n+1})$	k
A ₁	$(7\ell + 1, \ell, -1)$	$7\ell + 2$
A ₂	$(5\ell + 1, \ell, -1)$	$5\ell + 2$
B	$(6\ell - 1, 2\ell - 1, -2, -1)$	$6\ell + 1$
C ₁	$(7\ell + 3, 5\ell + 2, 3\ell + 1, -1)$	$7\ell + 2$
C ₂	$(7\ell + 5, 3\ell + 2, 2\ell + 1, \ell, -1)$	$7\ell + 4$
D ₁	$(13\ell + 3, 9\ell + 2, 5\ell + 1, \ell, -1)$	$13\ell + 2$
D ₂	$(13\ell + 9, 3\ell + 2, 2\ell + 1, \ell, -1)$	$13\ell + 8$
E ₁	$(27\ell + 5, 11\ell + 2, 6\ell + 1, \ell, -1)$	$27\ell + 4$
E ₂	$(27\ell + 11, 5\ell + 2, 3\ell + 1, \ell, -1)$	$27\ell + 10$
F ₁	$(23\ell^2 + 21\ell + 3, 23\ell + 4, 6\ell + 1, \ell, -1)$	$23\ell + 3$
F ₂	$(23\ell^2 + 25\ell + 5, 23\ell + 6, 4\ell + 1, \ell, -1)$	$23\ell + 5$
G ₁	$(17\ell^2 + 14\ell + 2, 17\ell + 3, 6\ell + 1, \ell, -1)$	$17\ell + 2$
G ₂	$(17\ell^2 + 20\ell + 5, 17\ell + 6, 3\ell + 1, \ell, -1)$	$17\ell + 5$
H ₁	$(11\ell^2 + 10\ell + 2, 11\ell + 3, 4\ell + 1, \ell, -1)$	$11\ell + 2$
H ₂	$(11\ell^2 + 12\ell + 3, 11\ell + 4, 3\ell + 1, \ell, -1)$	$11\ell + 3$
I ₁	$(24\ell - 1, 15\ell - 1, 6\ell - 1, 3\ell - 2, 3, 1)$	$12\ell + 1$
I ₂	$(40\ell + 2, 22\ell + 1, 4\ell, 2\ell - 1, 2, 1)$	$20\ell + 2$
I ₃	$(24\ell + 2, 14\ell + 1, 4\ell, 2\ell - 1, 2, 1)$	$12\ell + 2$
J	$(-24\ell - 7, 15\ell + 4, -6\ell - 1, 3\ell - 1, 3, 1)$	$12\ell + 5$
K	$(13, -8, 3, -1)$	15

type	b -sequence
A	$(0, -1, 0, 1)$
B	$(0, -1, 0, 1, 0)$
CDE	$(0, -1, 0, 0, 1)$
FGH	$(0, 0, 1, 0, 0, -1)$
IJ	$(0, 0, 1, 0, -1, 0, 0)$
K	$(0, -1, 0, -1, 1)$

TABLE 9. Tables of the sequence $(p_3, p_4, \dots, p_{n+1})$ for the continued fractions of p/q for $L(p, q)$ in FIGURE 2 and b -sequences.

3.3.1. *To find $\tilde{K}_{p,k}$ in the pillowcase (Appendix 1).* In Appendix 1 we untwist the pillowcase and K' for $K_{p,k}$ to end up the pillowcase with the slope 0 or ∞ according to the a -sequence in TABLE 8. For example, FIGURE 19 presents pillowcase method for A₁ type knots. We omit the writing slope lines (as (1)-(4) in FIGURE 12) and describe $(P/Q, \gamma, K')$ and h -sequence only. The first picture is $((14\ell^2 + 7\ell + 1)/(7\ell^2 + 7\ell + 1), \gamma, K')$ and $7\ell + 2$ and γ is the 2-component arcs with the four end points attached at the vertices of pillowcase and K' is the segment from one component of γ to a point in α_0 . We untwist K' and the picture becomes the 2nd picture, and untwist the pillowcase (3rd picture). By iterating these methods alternatively, we obtain the last picture in FIGURE 19.

In the similar way to this case, we obtain each pillowcase with slope 0 or ∞ according to the a -sequence of the type.

3.3.2. *To find $\tilde{K}_{p,k}$ in $L(p, k^2)$ (Appendix 2).* We move our procedure to Appendix 2. By using the Montesinos trick, we develop K' from the last picture of Appendix 1 along the 2-bridge knot or link. Then we obtain a knot $\tilde{K}_{p,k}$ in the chain of unknots. The framing is uniquely determined so that the surgery can obtain a homology sphere.

Type	Pillowcase	$\tilde{K}_{p,k}$	$K_{p,k}$	Extension
A	19	26	33	34
B	20	27	35	36
CDE	21	28	37	39
FGH	22	29	38	39
I	23	30	40	41
J	24	31	42	43
K	25	32	44	45

TABLE 10. The figure numbers for the processes to obtain $\tilde{K}_{p,k}$ and $K_{p,k}$.

3.3.3. *To find $K_{p,k}$ in $Y_{p,k}$ (to the first pictures in Appendix 3).* The last pictures in Appendix 2 are Kirby diagrams of homology sphere $Y_{p,k}$ for TABLE 2. We give a knot diagram of $K_{p,k}$ by the usual way. By attaching 0-framed meridian to $\tilde{K}_{p,k}$ and trivializing the diagram other than the 0-framed meridian to deform into the diagram of $S(1, (2, 1), (3, 1), (5, 1))$. Then we obtain a knot in the diagram. This is the knot diagram $K_{p,k}$ in the Poincaré homology sphere $\Sigma(2, 3, 5)$ ($K_{p,k}$ in Appendix 3). The knot diagrams are described to extend the underlying space to other homology spheres later on (Section 4).

3.3.4. *To check $\Sigma(2, 3, 5)_p(K_{p,k}) = L(p, k^2)$.* To check that the first diagrams in Appendix 3 is $K_{p,k}$ in the case of $Y_{p,k} = \Sigma(2, 3, 5)$, we can do the Kirby calculus for the Dehn surgery descriptions along the processes in Appendix 3. Each last graph in the sequence of figures is a plumbing diagram. This diagram is defined in [13]. Each of resulting linear plumbing diagrams gives the lens space $L(p, k^2)$. This means that the surgeries are all positive integral surgeries in $\Sigma(2, 3, 5)$ by using Lemma 2.3 and b -sequence. This fact can be also checked by [15].

TABLE 10 presents the index of the figure numbers per each type. As b -sequences in TABLE 9 are indicated, we have only to do a sequence of processes, for six patterns: A, B, CDE, FGH, IJ, and K types. We call the plumbing diagram containing X type surgery *X type plumbing diagram*.

3.4. $K_{p,k}$ in $\Sigma(2, 3, 7)$. Here we prove Theorem 1.3.

Proof. The Seifert data of $\Sigma(2, 3, 7)$ is $-S(1, (2, 1), (3, 1), (7, 1))$. Thus we can give Kirby diagram of $\Sigma(2, 3, 7)$ by replacing the multiplicity 5 in $\Sigma(2, 3, 5)$ with 7 and reversing the orientation.

By doing the pillowcase method (untwisting pillowcase and K' (in the sense of Section 3.2)) for $\tilde{K}_{p,k}$ in the list of TABLE 2, we obtain the pillowcases corresponding to FIGURE 19 to 25. These knots are realized as $K_{p,k}$ in $\Sigma(2, 3, 7)$, by seeing the b -sequence. Appendix 2 and 3 include these families.

Finally, we prove that the surgeries are all positive integral surgeries. For example, by substituting $(7, 3)$ for (a, b) in FIGURE 26, we get the following continued fraction

$$[2, \ell + 1, 9, -\ell] = (18\ell^2 + 9\ell + 1)/(9\ell^2 + 9\ell + 1),$$

$$(p_2, p_3, p_4, p_5) = (9\ell^2 + 9\ell + 1, 9\ell + 1, \ell, -1).$$

The lens space is $L(18\ell^2 + 9\ell + 1, 9\ell^2 + 9\ell + 1) = L(18\ell^2 + 9\ell + 1, -(9\ell + 2)^2)$. Here recall that this type is A. The b -sequence is $(0, 1, 0, -1)$ for the case of $\Sigma(2, 3, 5)$. In the present case $(0, -1, 0, 1)$ should be the b -sequence because the orientation is the opposite direction. Thus the dual class is $k = 9\ell + 2$. Since this surgery is performed in $-\Sigma(2, 3, 7)$, Lemma 2.3 tells us that this family gives positive integral

surgeries. By doing the same procedure, the families in TABLE 3 are all positive surgeries. \square

4. LENS SPACE SURGERIES IN BRIESKORN HOMOLOGY SPHERES.

In Appendix 3, we generalize the lens surgeries to plumbed 3-manifold surgeries in plumbed homology spheres other than S^3 and $\Sigma(2, 3, 6 \pm 1)$. Hence, it is easy to give some lens surgeries in Brieskorn homology spheres or several plumbed homology spheres. We give the graph deformation as in TABLE 18. Each deformation in the list means that some integral Dehn surgery of a knot in the left plumbing 3-manifold is deformed into the right plumbed 3-manifold. In this section we compute lens space surgeries over Brieskorn homology spheres.

4.1. Lens space surgeries in Brieskorn homology spheres derived from the list of TABLE 2.

4.1.1. *A type lens space knots.* The pillowcase method of an A type dual knot $\tilde{K}_{p,k}$ is basically given in FIGURE 19. By using double covering of 2-bridge knots or links (the Montesinos trick as in [9]), we get $\tilde{K}_{p,k}$ in lens spaces as in FIGURE 26. Here the cases of $(a, b) = (3, 5)$ and $(5, 3)$ correspond to A_1 and A_2 respectively. By Montesinos trick for the 2-bridge knot (or link) with arc K' (in the sense of Section 3.2) we obtain knot $\tilde{K}_{p,k}$ in the lens space FIGURE 26. By Corollary 2.2, the 0-framing in FIGURE 26 for integral $\mathbb{Z}HS$ -surgery is uniquely determined. Thus, for the slope, we have only to compute the order of H_1 . Hence, the knot $K_{p,k}$ is described as in the left picture in FIGURE 33. Here we attach 0-framed meridian of $\tilde{K}_{p,k}$ in FIGURE 26 and move the Kirby diagram other than the meridian to the diagram as in FIGURE 3. This is already explained as the first example in Section 3.3.3.

These surgeries are generalized to knots in the Seifert manifolds as the left picture in FIGURE 13. If these diagrams present homology spheres, then the integer a must be odd number because another multiplicity is 2. These diagrams give Brieskorn homology spheres as in TABLE 7. Note that to get the usual orientations of the Brieskorn homology spheres, we must change the orientation of the diagram, if necessary. Then there are examples of the following Brieskorn homology spheres with A type. Here s, s', m are positive integers. As examples satisfying these conditions, we illustrate the below.

Proposition 4.1. *There exist double-primitive knots $K_{p,k}$ in the following Brieskorn homology spheres*

- $\Sigma(2, 2s + 1, 2(2s + 1) \pm 1)$
($a = 2(2s + 1) \pm 1$ and $b = (2s + 1)/s$).
- $\Sigma(2, 2s \pm 1, 2am - s)$
($a = 2s \pm 1$, $b = (2am - s)/((a - 2)m - s')$, and $s = 2s' + 1$)
- $\Sigma(2, 2s \pm 1, 2am + s)$
($a = 2s \pm 1$, $b = (2am + s)/((a - 2)m + s')$, and $s = 2s' + 1$)

such that the resulting lens space $L(p, q)$ are

$$[\beta_r, \dots, \beta_1 - 1, \ell + 1, a + 2, -\ell],$$

where $b = [\beta_1, \dots, \beta_r]$.

Proof. That such a Brieskorn homology sphere includes $K_{p,k}$ is obtained by substituting the indicated values for the parameters a, b in the extended Dehn surgery in FIGURE 33 in Appendix 3. Here note that one must change the orientation if necessary. \square

Here we illustrate the way to give the dual class for the example. The b -sequence of the lens surgery corresponds to the extension of the sequence of A type knot in TABLE 9. Therefore, such a knot is realized as $K_{p,k}$.

Here we compute the first example as above with the plus case only:

$$p/q = [s, -1, -\ell - 1, -2(2s+1) - 3, \ell] = ((4s^2 + 9s + 5)\ell^2 + (4s + 5)\ell + 1)/(4s + 5)\ell^2$$

$$L(p, q) = L((4s^2 + 9s + 5)\ell^2 + (4s + 5)\ell + 1, ((4s + 5)\ell + 2)^2)$$

$$(p_2, p_3, p_4, p_5, p_6) = ((4s + 5)\ell^2, -(4s + 5)\ell^2 - (4s + 5)\ell - 1, (4s + 5)\ell + 1, \ell, -1).$$

Thus the b -sequence is

$$(b_1, b_2, b_3, b_4, b_5) = (0, 0, 1, 0, -1).$$

Thus the dual class is $(4s + t)\ell + 2$. This means that these p -surgeries over $\Sigma(2, 2s + 1, 2(2s + 1) + 1)$ give lens spaces as above. Doing the pillowcase method along these data, we can obtain the straight extension of FIGURE 19.

Remark 4.1. The method of this proof of Proposition 4.1 is available for other propositions in this section. If we give no proof to them, it is regarded as omitting the proof.

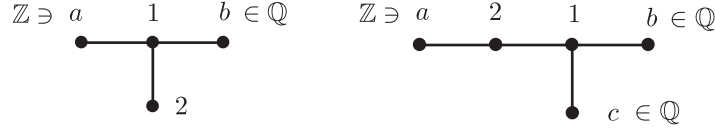

FIGURE 13. A and B type plumbing diagrams.

Proof of Proposition 1.15 in the case of lens space knot in $\Sigma(2, 5, 7)$ with type A. The Seifert data of $\Sigma(2, 5, 7)$ is $-S(1, (2, 1), (5, 1), (7, 2))$. We suppose that $B = [3, -2]$ and $a = 5$ and $A = \emptyset$ on A type surgery in FIGURE 18. Then we can obtain a family of lens spaces with continued fraction:

$$[-2, 3, 1, \ell + 2, 7, -\ell] = -\frac{35\ell^2 + 21\ell + 3}{14\ell^2 + 7\ell + 1}$$

$$L(35\ell^2 + 21\ell + 3, 14\ell^2 + 7\ell + 1) = L(35\ell^2 + 21\ell + 3, (7\ell + 2)^2)$$

$$(p_2, p_3, p_4, p_5) = (14\ell^2 + 7\ell + 1, 7\ell^2, -7\ell - 1, \ell, 1)$$

and b -sequence is $(0, 0, -1, 0, 1)$. Thus this is an A type surgery. From Corollary 2.3 the surgeries are all positive integral surgeries on $\Sigma(2, 5, 7)$. \square

Specially, the case of $\ell = -1$ is the lens space surgery $\Sigma(2, 5, 7)_{17}(K) = L(17, 15)$, which is appeared in Section 1.3.

4.1.2. *B type lens space knots.* The pillowcase method and the double branched covering for B type dual knot $\tilde{K}_{p,k}$ are given in FIGURE 20 and 27. Then B type plumbing diagram is the left in FIGURE 13. The B type Seifert data up to orientation is

$$S(1, (2a - 1, a), (b_1, b_2), (c_1, c_2)).$$

For example, the following Brieskorn homology spheres are included. Here s, n are positive integers and $b = b_1/b_2$ and $c = c_1/c_2$ are rational numbers.

Proposition 4.2 (B type lens space surgery). *There exist double-primitive knots $K_{p,k}$ in the following Brieskorn homology spheres*

- $\Sigma(2, 2s + 1, 2(2s + 1)n \pm 1)$ ($a = -s$, $b = 2$, and $c = 2(2s + 1) \pm 1/n$)
- $\Sigma(3, 12s - 8, 18s - 13)$ ($a = -9s + 7$, $b = 3$ and $c = (12s - 8)/(2s - 1)$)
- $\Sigma(3, 12s - 8, 18s - 11)$ ($a = -9s + 6$, $b = 3$ and $c = (12s - 8)/(2s - 1)$)

- $\Sigma(3, 6s - 1, 18s - 5)$ ($a = -9s + 3$, $b = 3$ and $c = (6s - 1)/s$)
- $\Sigma(3, 6s - 1, 18s - 1)$ ($a = -9s + 1$, $b = 3$ and $c = (6s - 1)/s$)
- $\Sigma(3, 6n - 1, 3(6n - 1)s \pm x)$
 $(a = -3n + 1$, $b = 3$, and $c = (3(6n - 1)s \pm x)/((3n + 1)s \pm y)$, where x, y
are some integers satisfying $(3n + 1)x - 3(6n - 1)y = \pm 1$).
- $\Sigma(3, 6n + 1, 3(6n + 1)s \pm x)$
 $(a = -3n$, $b = 3$, and $c = (3(6n + 1)s \pm x)/((3n + 2)s \pm y)$, where x, y are
some integers satisfying $(3n + 2)x - 3(6n + 1)y = \pm 1$).

such that the resulting lens spaces $L(p, q)$ are of the form

$$p/q = [\beta_r, \dots, \beta_1, \ell, a, 2, -\ell + 1, \gamma_1, \dots, \gamma_s],$$

where $b_1/b_2 = [\beta_1, \dots, \beta_r]$ and $c_1/c_2 = [\gamma_1, \dots, \gamma_s]$.

We list examples for a negative integer a and a rational b with $b \leq 3$ above, while one can also find B type lens space knots with positive a or higher b . The family of B type with $a = -1$ is symmetric if one exchanges the roles of b and c . Thus we could find a pair of two families of type B. If a is not -1 , then we can find two families of type B lens space knots. For example, deal with the first example in the list above. Then we can find two families B_1, B_2 as below. Below, we describe the resulting lens spaces obtained by type B_1 and B_2 . We state the result here.

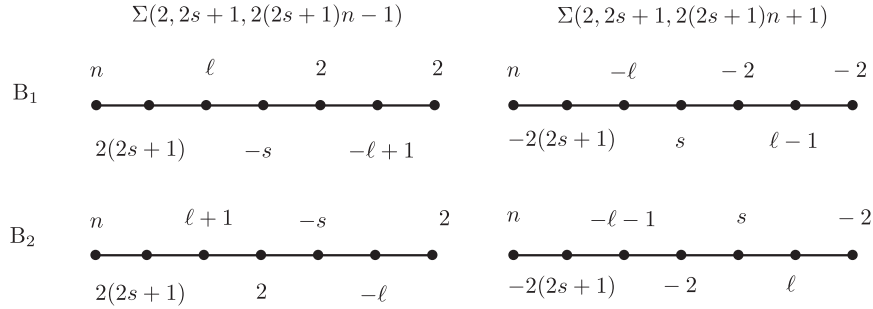

FIGURE 14. B_1 : $a = -s$, $b = 2(2s + 1) \pm 1/n$, $c = 2$; B_2 : $a = -s$,
 $b = 2$ and $c = 2(2s + 1) \pm 1/n$ in $\Sigma(2, 2s + 1, 2(2s + 1)n \pm 1)$.

Proposition 4.3 (B type lens space surgery). *There exist double-primitive knots $B_{p,k}$ in the Brieskorn homology spheres $\Sigma(2, 2s + 1, 2(2s + 1)n \pm 1)$ with the following coefficients $a = -s$ and, b, c in FIGURE 13.*

- (B_1 type)
 - $\Sigma(2, 2s + 1, 2(2s + 1)n - 1)$ ($b = 2(2s + 1) - 1/n$, and $c = 2$)
 - $\Sigma(2, 2s + 1, 2(2s + 1)n + 1)$ ($b = 2(2s + 1) + 1/n$, and $c = 2$)
- (B_2 type)
 - $\Sigma(2, 2s + 1, 2(2s + 1)n - 1)$ ($b = 2$, and $c = 2(2s + 1) - 1/n$)
 - $\Sigma(2, 2s + 1, 2(2s + 1)n + 1)$ ($b = 2$, and $c = 2(2s + 1) + 1/n$)

such that the resulting lens spaces $L(p, q)$ is represented in FIGURE 14.

4.1.3. *CDE type lens space knots.* Next, consider CDE type lens space knots in Brieskorn homology spheres. The pillowcase and double branched covering methods are in FIGURE 21 and 28 respectively. In the deformation of CDE type in FIGURE 18, we assume that the A, B, C, D are all single chains of unknots. Then homology spheres of these types are of form of the left of FIGURE 15 for and $a, b, d, s \in \mathbb{Q}$.

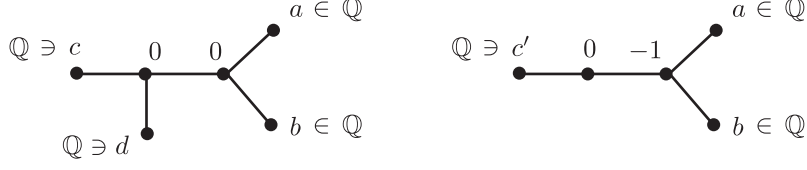

FIGURE 15. CDE type and FGH type plumbing diagrams.

For example, the plumbing diagrams of the cases of $\{a, b\} = \{1, 2\}$ and $(c, d) = (5, 2)$ in FIGURE 18 are $\Sigma(2, 3, 5)$ and the deformations are C type lens space knots in TABLE 2.

We assume that $a = 1$ or $b = 1$ and $d = m/(m-1)$ for an integer m with $m \neq 1$. Furthermore, the following cases produce Brieskorn homology spheres.

$$[1] a = 1 \quad [2] b = 1 \quad [3] c = \pm 1$$

Consider the cases [1] or [2]. The Seifert data are $S(1, (m, m-1), (b+1, 1), (c_1, c_2))$ and $S(1, (m, m-1), (a+1, 1), (c_1, c_2))$ respectively where $c = c_1/c_2$. In the case of $m = 2$, we obtain CD type in TABLE 2. For example, $\Sigma(2, 5, 7)$ ($m = 2, b+1 = 5$, and $c = 7/2$) or $\Sigma(3, 10, 13)$ ($m = 3, b+1 = 10$ and $c = 13/3$). These surgeries are called CD type. Furthermore, C_1D_1 type means the case of $a = 1$ and C_2D_2 type means the case of $b = 1$.

Consider the case of [3]. If $c = -1$ holds, then the Seifert data is $S(-1, (a, 1), (b, 1), (1, m-1))$. The possible case is S^3 only. In the case of $c = 1$, the Seifert data is $S(1, (2m-1, m-1), (b, 1), (a, 1))$. For example, $\Sigma(3, 4, 5)$ ($m = 3, a = 3, b = 4$) $\Sigma(4, 5, 9)$ ($m = -4, a = 4$, and $b = 5$). These cases are called E type. As a result we obtain the following proposition:

Proposition 4.4 (CDE type lens space surgery). *The Brieskorn homology spheres with the following Seifert data*

- (i) $S(1, (m, m-1), (b+1, 1), (c_1, c_2))$ (C_1D_1 type)
- (ii) $S(1, (m, m-1), (a+1, 1), (c_1, c_2))$ (C_2D_2 type)
- (iii) $S(1, (2m-1, m-1), (b, 1), (a, 1))$ (E type)

contain $K_{p,k}$ and the resulting lens spaces $L(p, q)$ satisfy

$$\begin{aligned} p/q &= [\gamma_n, \gamma_{n-1}, \dots, \gamma_1, \ell, -m-1, b, -\ell], \\ p/q &= [\gamma_n, \gamma_{n-1}, \dots, \gamma_1, \ell+1, a, -m-1, -\ell-1]. \\ p/q &= [2, \ell+1, a, -m, b-\ell] \end{aligned}$$

respectively. In the case of (i) or (ii) the continued fraction $[\gamma_1, \gamma_2, \dots, \gamma_n]$ presents $(c_1 + c_2)/c_2$.

Furthermore we can give other examples.

Proposition 4.5 (CDE type lens space surgery). *There exist double-primitive knots $K_{p,k}$ in the following Brieskorn homology spheres.*

- (iv) $\Sigma(2, 3, 6n \pm 1)$ ($m = 2, \{a, b\} = \{1, 3\}$, and $c_1/c_2 = 6 \pm 1/n$) (C type)
- (v) $\Sigma(2, 2s+1, 2(2s+1) \pm 1)$
 - ($m = 2, \{a, b\} = \{1, 2(2s+1) \pm 1 - 1\}$ and $c = (2s+1)/s$) (D type)
 - ($m = s+1, \{a, b\} = \{2, 2(2s+1) \pm 1\}$ and $c = 1$) (E type)

The cases where the homology spheres with CDE type plumbing diagram are graph manifolds are remained. These cases will be written in later section.

Here we prove the remaining part of Proposition 1.15.

Proof of Proposition 1.15 in the cases of $\Sigma(2, 5, 7)$, $\Sigma(3, 4, 5)$ with CDE

type. In the case of $(c_1 + c_2)/c_2 = 7/2 + 1 = 9/2 = [5, 2]$, $m = 2$ and $b = 4$ or $a = 4$, the lens spaces $L(p, q)$ are

$$[2, 5, \ell, -3, 4 - \ell] = \frac{117\ell^2 + 37\ell + 3}{65\ell^2 + 22\ell + 2}$$

$$[2, 5, \ell + 1, 4, -3, -\ell - 1] = \frac{117\ell^2 + 145\ell + 45}{65\ell^2 + 82\ell + 26}$$

respectively. The dual classes are $13\ell + 2$ and $13\ell + 8$ because the b -sequence of these examples corresponds to that of the CD type surgery.

This Seifert presentation of $\Sigma(3, 4, 5)$ is $-S(1, (3, 1), (4, 1), (5, 2))$. In the case of $m = 3$ and $(a, b) = (3, 4)$ or $(4, 3)$ for E type lens space surgery we obtain the following lens spaces $L(p, q)$.

$$p/q = [2, \ell + 1, 3, -3, 4 - \ell] = \frac{86\ell^2 + 37\ell + 4}{43\ell^2 + 40\ell + 7}$$

$$p/q = [2, \ell + 1, 4, -3, 3 - \ell] = \frac{86\ell^2 + 49\ell + 7}{43\ell^2 + 46\ell + 10}$$

The dual class is $43\ell + 9$ and $43\ell + 12$, because the b -sequences of E type surgery corresponds to the one of E type surgery. \square

4.1.4. *FGH type lens space knots.* The case that the parameter m in the CDE type surgery is equal to 1, equivalently $d = \infty$ is remaining. This case also should become some lens space surgeries. Actually, the pillowcase and double covering method are FIGURE 22 and 29. In FIGURE 18 we extend deformations of FGH type surgery to deformations of plumbing diagrams. We call such a surgery *FGH type surgery*.

We assume that the links in A, B and C in FIGURE 18 are single linear chains. Then we obtain the right picture in FIGURE 15. Here a, b, c' are rationals. Furthermore, if the resulting manifolds are lens spaces, then we can find $a, b \in \mathbb{Z}$ and $c' \in \mathbb{Q}$. In the case of $d = 2$, $c' = d - 1/c = (2c - 1)/c$ for integers c , and $\{a, b, c\} = \{2, 3, 5\}$ or $\{2, 3, 7\}$ we have FGH type of $\Sigma(2, 3, 5)$, or $\Sigma(2, 3, 7)$ respectively. Thus the Seifert data yielding lens spaces are $S(1, (a, 1), (b, 1), (c_1, c_2))$, where $c = c_1/c_2$.

For example, we obtain the following proposition.

Proposition 4.6 (FGH type lens space surgery). *There exist double-primitive knots $K_{p,k}$ in the following Brieskorn homology spheres*

- (i) $\Sigma(2, 3, 6n \pm 1)$ ($\{a, b\} = \{2, 3\}$ and $c_1/c_2 = 6 \pm 1/n$) (*H type*),
- (ii) $\Sigma(2, 2s + 1, 2(2s + 1) \pm 1)$ ($\{a, b\} = \{2, 2(2s + 1) \pm 1\}$ $c = 2 + 1/s$) (*G type*)

such that the resulting lens spaces are

$$[\mp n, 6, 2, \ell + 1, 3, 4, -\ell], [\mp n, 6, 2, \ell + 1, 4, 3, -\ell]$$

and

$$[-s, 2, 2, \ell + 1, 3, 2(2s + 1) \pm 1 + 1, -\ell], [-s, 2, 2, \ell + 1, 2(2s + 1) \pm 1 + 1, 3, -\ell]$$

respectively.

4.1.5. *IJ type lens space knot.* First, consider I type lens space knots in Brieskorn homology spheres. Due to FIGURE 18, if the A and B are two unknots with rational framings a, b , integral framing c and empty C , then the resulting manifold is a lens space. Then, the Seifert data of the Brieskorn homology spheres are $S(1, (a_1, a_2), (b_1, b_2), (c, 1))$, where $a = a_1/a_2$ and $b = b_1/b_2$.

Proposition 4.7 (I type lens space surgery). *There exist double-primitive knots $K_{p,k}$ in the following Brieskorn homology spheres $\Sigma(2, 2s + 1, 2(2s + 1)n \pm 1)$ such that*

- (i) $\Sigma(2, 2s + 1, 2(2s + 1)n \pm 1)$ ($a_1/a_2 = 2(2s + 1) \pm 1/n$, $b_1/b_2 = (2s + 1)/s$, and $c = 2$) (I_1 type)
 - (ii) $\Sigma(2, 2s + 1, 2(2s + 1) \pm 1)$
 - (a) $a_1/a_2 = 2(2s + 1) \pm 1$, $b_1/b_2 = (2s + 1)/s$ and $c = 2$ (I_1 type)
 - (b) $a_1/a_2 = (2s + 1)/s$, $b_1/b_2 = 2$ and $c = 2(2s + 1) \pm 1$ (I_2 type)
 - (iii) $\Sigma(2, 3, 6n \pm 1)$
 - (a) $a_1/a_2 = 6 \pm 1/n$, $b_1/b_2 = 3$ and $c = 2$ (I_1 type)
 - (b) $a_1/a_2 = 6 \pm 1/n$, $b_1/b_2 = 2$ and $c = 3$ (I_3 type)
- such that the resulting lens spaces $L(p, q)$ satisfy with
- (1) $p/q = [\alpha_n, \dots, \alpha_1, \ell + 1, -2, c, -2, -\ell, \beta_1, \beta_2, \dots, \beta_m]$,
 where $a_1/a_2 = [\alpha_1, \dots, \alpha_n]$ and $b_1/b_2 = [\beta_1, \beta_2, \dots, \beta_m]$ for $\alpha_i, \beta_j \in \mathbb{Z}$.

Further, there are many other examples.

Proposition 4.8 (I type lens space surgery). *There exist double-primitive knots $K_{p,k}$ in the following Brieskorn homology spheres*

- (iv) $\Sigma(3, 3n + 1, 12n + 5)$ ($a_1/a_2 = [3, -n]$, $b_1/b_2 = [3, n + 1, 4]$, $c = 3$ ($n > 0$)) (I type),
- (v) $\Sigma(3, 9n + 4, 18n + 5)$ ($a_1/a_2 = [5, 2, n + 1]$, $b_1/b_2 = [3, 2, 2, 2, n, 2]$, $c = 3$, ($n > 0$)) (I type),

such that the resulting lens spaces $L(p, q)$ satisfy (1), equivalently the continued fraction can be deformed as follows:

$$p/q = [-n, 3, \ell + 1, 2, 4, 2, -\ell + 1, 3, n + 1, 4],$$

$$p/q = [n + 1, 2, 5, \ell + 1, 2, 4, 2, -\ell + 1, 3, 2, 2, 2, n, 2]$$

respectively.

Next, consider J type lens space surgery. If a Brieskorn homology sphere admits Seifert data $S(1, (2, 1), (a_1, a_2), (b_1, b_2))$, then we can do the Dehn surgery of FIGURE 42 of 43. Then the resulting manifolds are lens spaces $L(p, q)$ with

$$p/q = [\alpha_n, \dots, \alpha_1, \ell + 1, 3, 3, -\ell, \beta_1, \beta_2, \dots, \beta_m],$$

where $a_1/a_2 = [\alpha_1, \dots, \alpha_n]$ and $b_1/b_2 = [\beta_1, \beta_2, \dots, \beta_m]$ for $\alpha_i, \beta_j \in \mathbb{Z}$.

Proposition 4.9 (J type lens space surgery). *There exist double-primitive knots $K_{p,k}$ in Brieskorn homology spheres $\Sigma(2, 2s + 1, 2(2s + 1)n \pm 1)$, $\Sigma(2, 4n + 1, 12n + 5)$ and $\Sigma(2, 8n + 3, 12n + 5)$ satisfying the following coefficients A, B, c in FIGURE 18:*

- (vi) $\Sigma(2, 2s + 1, 2(2s + 1)n \pm 1)$ ($A = [2(2s + 1), \mp n]$, $B = [2, -s]$, $s > 0$),
- (vii) $\Sigma(2, 4n + 1, 12n + 5)$ ($A = [4, -n]$, $B = [4, n + 1, 3]$, $n > 0$),
- (viii) $\Sigma(2, 8n + 3, 12n + 5)$ ($A = [8n + 3]$, $B = [2, -2n, 3]$, $n > 0$),

such that the resulting lens spaces $L(p, q)$ of (vi), (vii), and (viii) are the following

$$p/q = [\mp n, 2(2s + 1), -\ell, 3, 3, \ell + 1, 2, -s],$$

$$p/q = [-n, 4, -\ell, 3, 3, \ell + 1, 4, n + 1, 3],$$

$$p/q = [8n + 3, -\ell, 3, 3, \ell + 1, 2, -2n, 3]$$

respectively.

According to [1] the homology spheres of (iv) (vii) bound rational 4-balls. Thus the resulting lens spaces bound 4-dimensional rational 2-spheres \mathcal{S} , namely $H_*(\mathcal{S}, \mathbb{Q}) = H_*(S^2, \mathbb{Q})$ and $\partial\mathcal{S} = L(p, q)$. These Brieskorn homology spheres are just examples of the J type lens space surgeries, hence, one can find double-primitive knots in other Brieskorn homology spheres of J type lens space surgery.

The resolution diagram of type II Brieskorn homology spheres with Seifert data $S(1, (2, 1), (a_1, a_2), (b_1, b_2))$ are classified in [8].

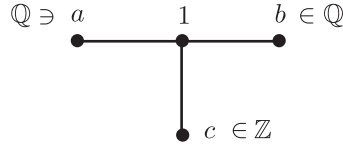

FIGURE 16. IJ type plumbing diagram.

4.1.6. *K type lens space knot.* We consider K type lens surgery. This case is exceptional in terms of quadratic family, because this family contains one example only in $\Sigma(2, 3, 5)$. The pillowcase method and double covering are FIGURE 25 and 32. From the extension of Dehn surgery in FIGURE 44 and 45, if the K type Seifert homology spheres yield lens spaces, then the Seifert data are $S(1, (3, 1), (m, m - 1), (a_1, a_2))$ is FIGURE 17.

Proposition 4.10 (K type lens space surgery). *There exists a double-primitive knot $K_{p,k}$ in the Brieskorn homology sphere $\Sigma(2, 3, 6n \pm 1)$ satisfying the following data:*

- (i) $\Sigma(2, 3, 6n \pm 1)$ ($m = 2$ and $a_1/a_2 = 6 \pm 1/n$) such that the resulting lens space $L(p, q)$ satisfy with

$$p/q = [\mp n, 6, 3, 3, 3, 2].$$

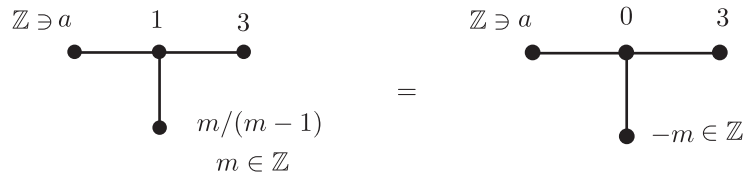

FIGURE 17. K type plumbing diagram.

4.2. **Proofs of Theorems.** In this section we prove the theorem stated in Section 1.

Proofs of Theorem 1.7, 1.9, and 1.10. Those proofs that those homology spheres contain these lens space knots immediately follows from propositions which are proven from Section 4.1.1 to Section 4.1.6. □

Proof of Theorem 1.14. As described in FIGURE 18, there exist graph homology spheres with not Brieskorn but CDE type plumbing diagram. We have only to check that the graph manifolds for the diagrams are homology spheres. □

4.3. **Dehn surgeries in S^3 as graph deformations in FIGURE 18.** Our method up to this point can be applied to construct some families of the lens space, connected sum of lens space and Seifert manifold surgeries in S^3 . Does this viewpoint have somehow relation to networking theory of Seifert surgeries by Deruelle, Miyazaki and Motegi in [4]? This may be clarified in future research.

In FIGURE 18 we give graph deformations coming from lens surgeries of $\Sigma(2, 3, 5)$. We illustrate that some graph deformations in these figures give families of lens space surgeries in S^3 . To clarify those examples one has only to check that the corresponding left diagrams in FIGURE 18 present S^3 .

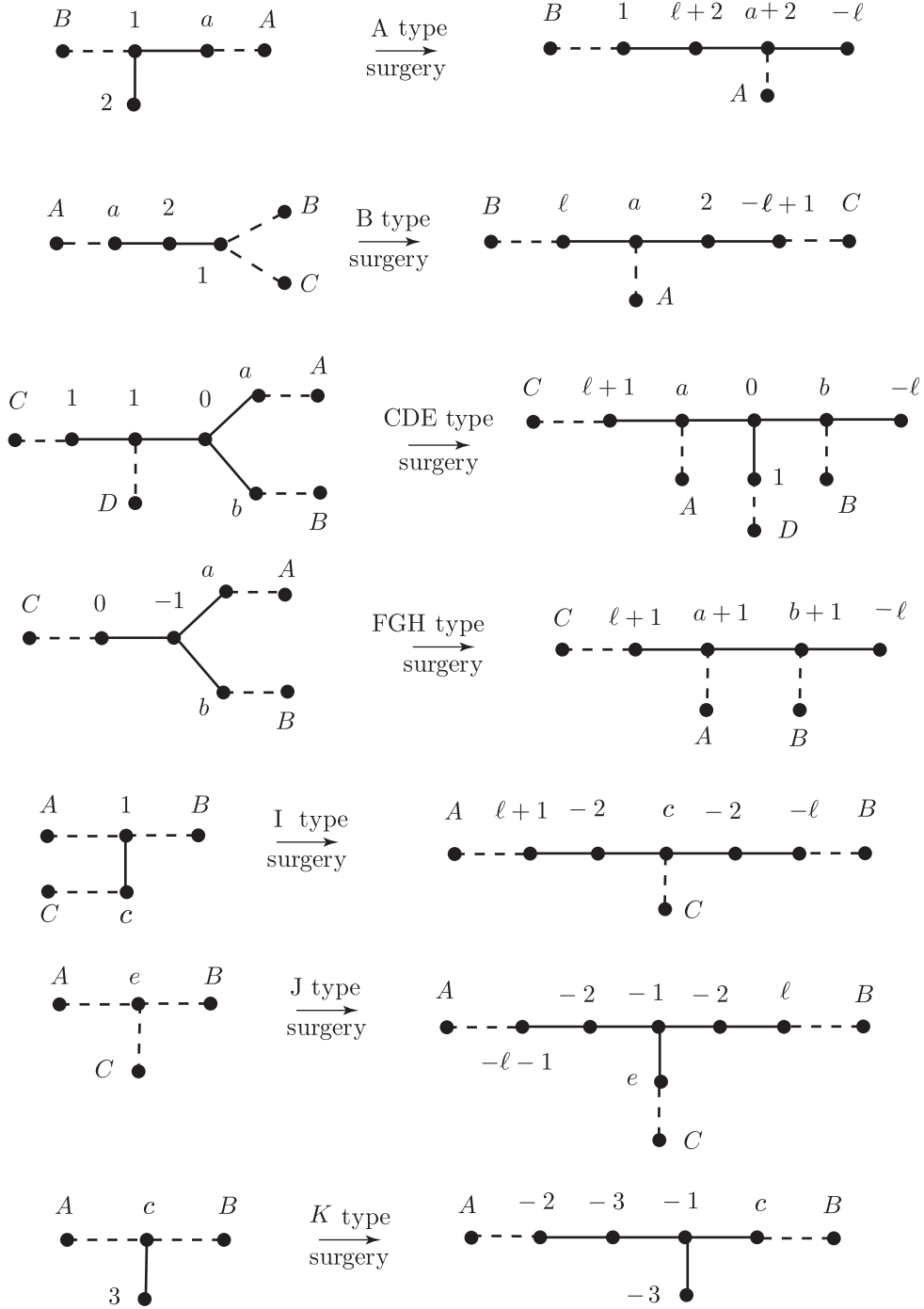

FIGURE 18. The deformations of plumbing diagrams obtained by extending lens space surgeries in $\Sigma(2, 3, 5)$.

Example 4.2. • In A type surgery set $a = 3$, $A = B = \emptyset$, then the resulting lens space is $L(5\ell^2 + 5\ell + 1, 5\ell^2)$ and $k = 5\ell + 2$. This family belongs to Berge's type VII.

- In A type surgery, set $A = [0]$, $B = [3]$, then the resulting manifolds are $L(2\ell + 1, \ell) \# L(\ell, -1)$. This family presents reducible surgeries on torus knots.
- In B type surgery in putting $A = [1]$, $B = [1, 2]$ and $C = [-1, -3]$, then the resulting lens spaces are $L(2\ell^2 - 11\ell + 14, 2\ell^2 - 9\ell + 11)$. This family is surgeries of $(2\ell - 5, \ell - 3)$ -torus knot.
- In J type surgery, set $A = [-1, -2, \dots, -2]$, $B = [1, 2, \dots, 2]$, and $C = [-1, -2, \dots, -2]$, $e = -a + b - c \pm 1$, where the lengths of arms are a, b and c . Then the resulting manifolds are Seifert manifold with Seifert data $S(-1, (2\ell - 2a + 1, a - \ell - 1), (-a + b \pm 1, 1), (2\ell - 2b + 1, b - \ell))$.

APPENDIX 1

In this appendix we give pillowcase methods (FIGURE 19, 20, 21, 22, 23, 24 and 25).

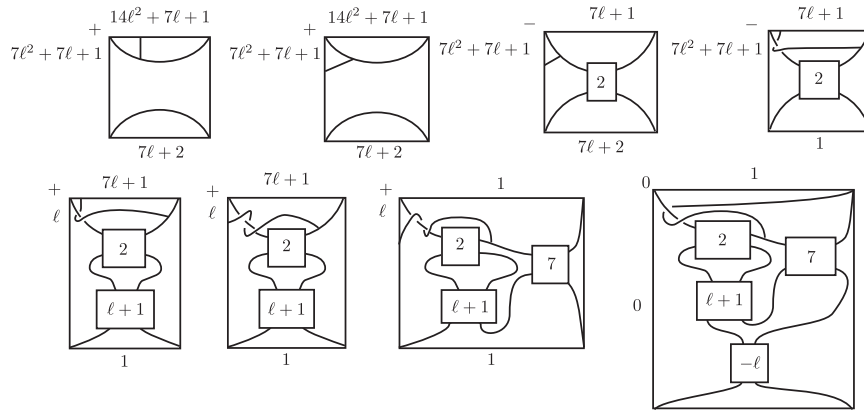

FIGURE 19. The pillowcase method for an A type simple $(1,1)$ -knot with the band (arc K' in the sense of Section 3.2).

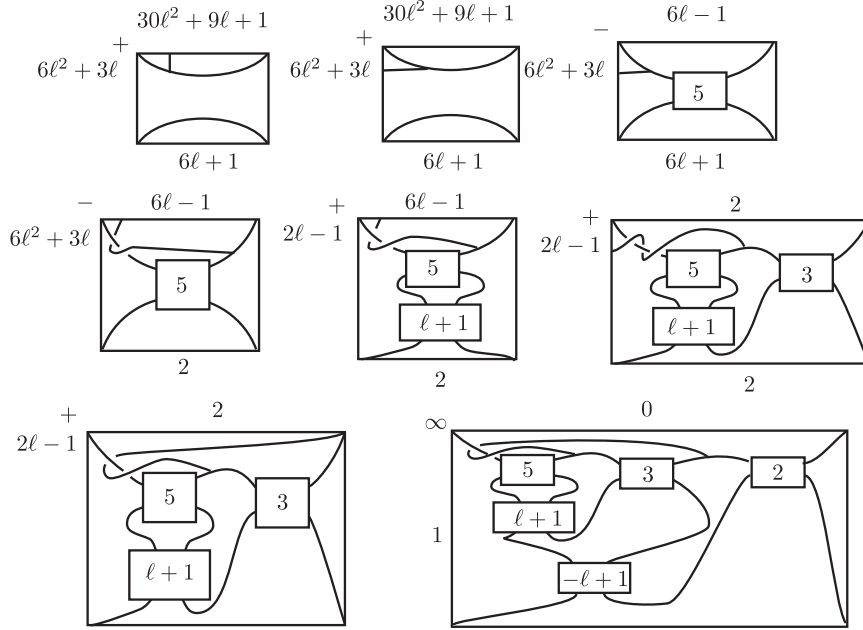

FIGURE 20. The pillowcase method for a B type simple (1,1)-knot with the band.

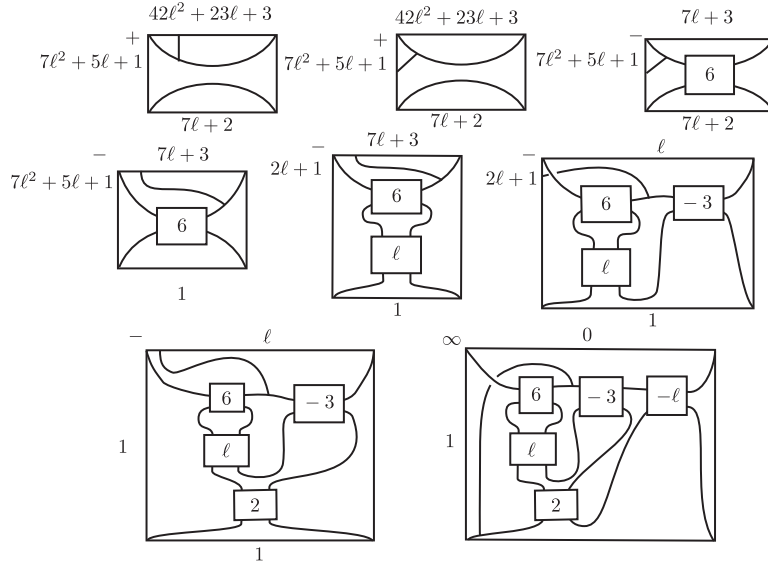

FIGURE 21. The pillowcase method for a CDE type simple (1,1)-knot with the band.

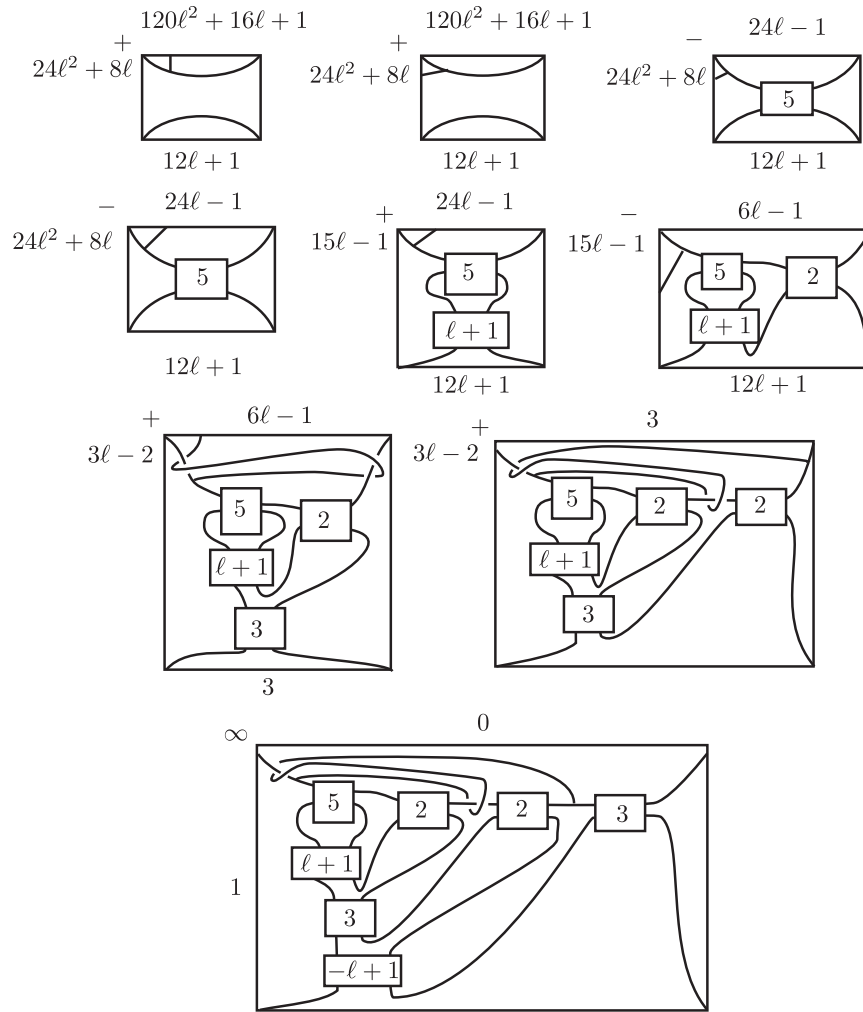

FIGURE 23. The pillowcase method for an I type simple (1,1)-knot with the band.

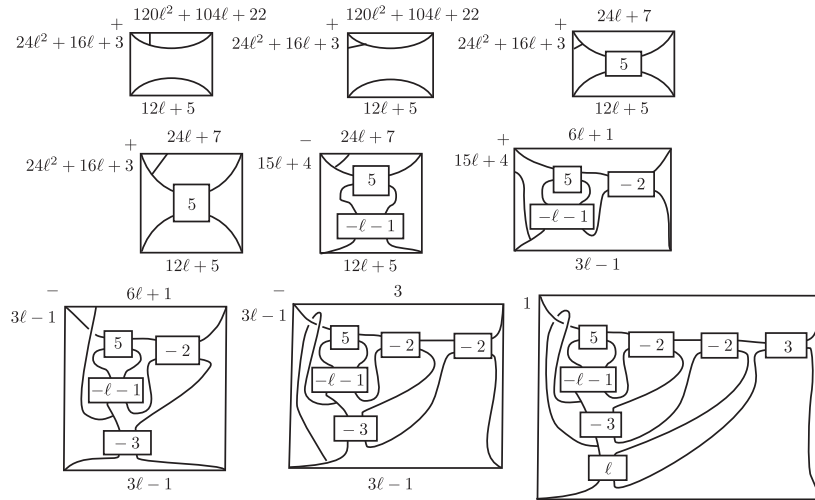

FIGURE 24. The pillowcase method for a J type simple (1,1)-knot with the band.

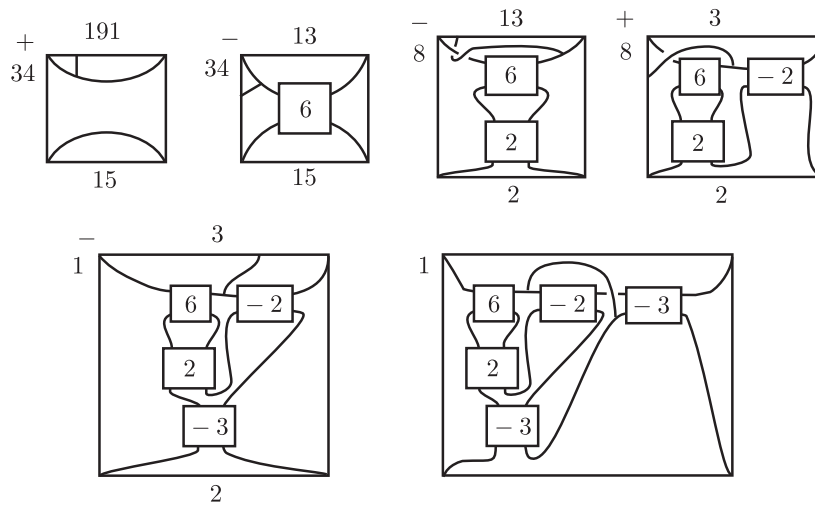

FIGURE 25. The pillowcase method for a K type simple (1,1)-knot with the band.

APPENDIX 2

In Appendix 2, we give double branched covering along the 2-bridge knot or link obtained in Appendix 1. In the covering space the attached arc in the 2-bridge knot or link is mapped to $\tilde{K}_{p,k}$. We describe the diagrams in generalized forms (FIGURE 26, FIGURE 27, FIGURE 28, FIGURE 29, FIGURE 30, FIGURE 31, and FIGURE 32).

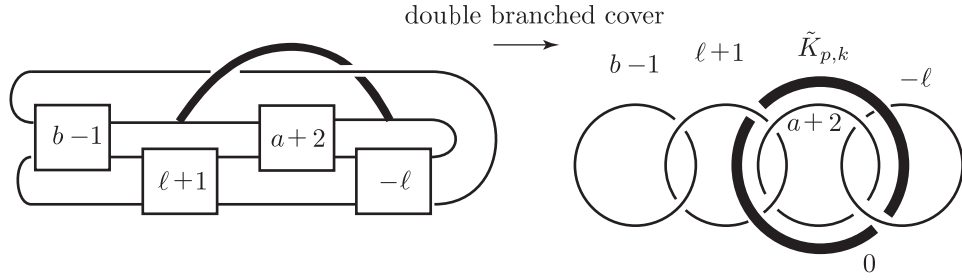

FIGURE 26. A type simple (1,1)-knot $\tilde{K}_{p,k}$ ($a \in \mathbb{Z}$, $b \in \mathbb{Q}$).

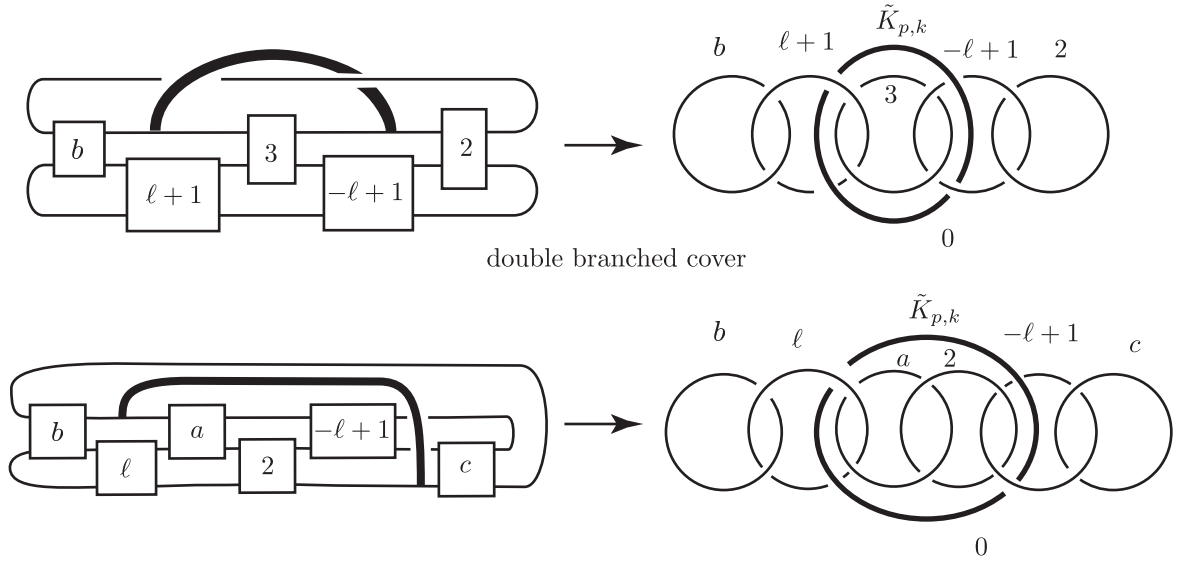

FIGURE 27. B type simple (1,1)-knot $\tilde{K}_{p,k}$ ($b, c \in \mathbb{Q}$, $a \in \mathbb{Z}$).

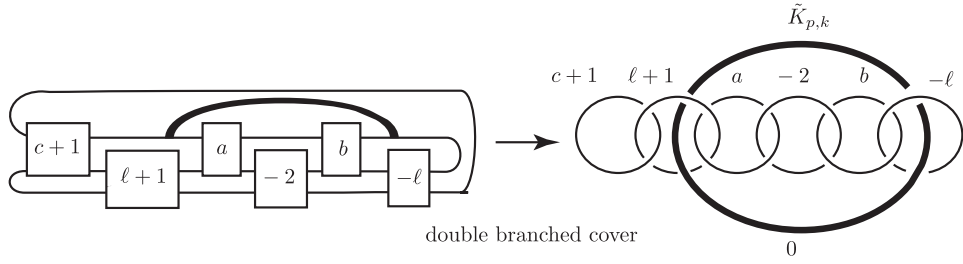

FIGURE 28. CDE type simple (1,1)-knot $\tilde{K}_{p,k}$ ($a, b \in \mathbb{Z}, c \in \mathbb{Q}$).

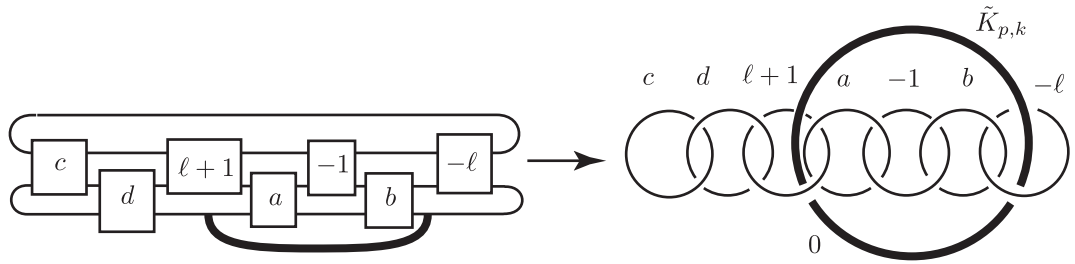

FIGURE 29. FGH type simple (1,1)-knot $\tilde{K}_{p,k}$ ($a, b, d \in \mathbb{Z}$ and $c \in \mathbb{Q}$).

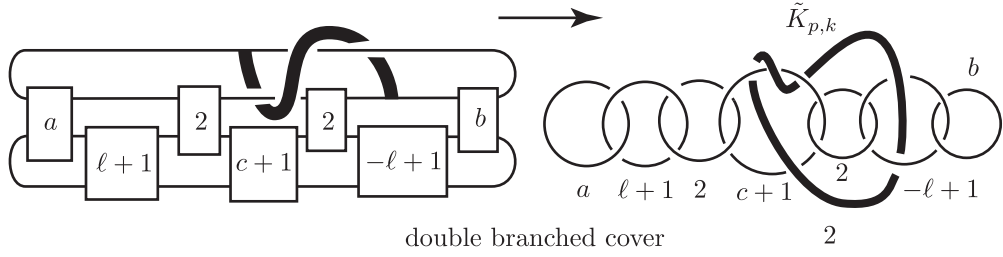

FIGURE 30. I type simple (1,1)-knot $\tilde{K}_{p,k}$ ($a, b \in \mathbb{Q}$ and $c \in \mathbb{Z}$).

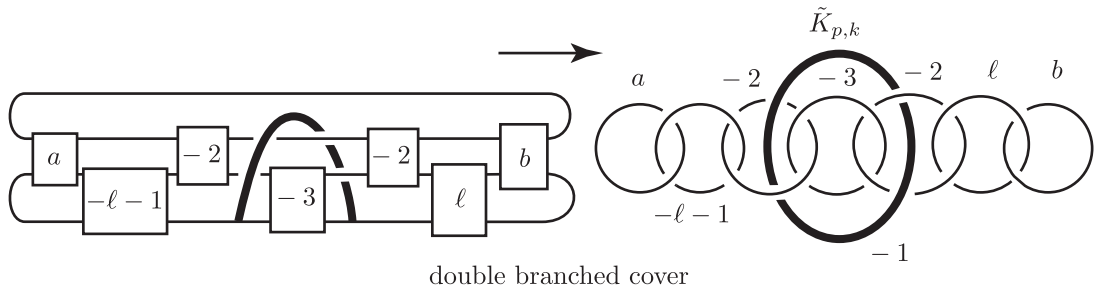

FIGURE 31. J type simple (1,1)-knot $\tilde{K}_{p,k}$ ($a, b \in \mathbb{Q}$).

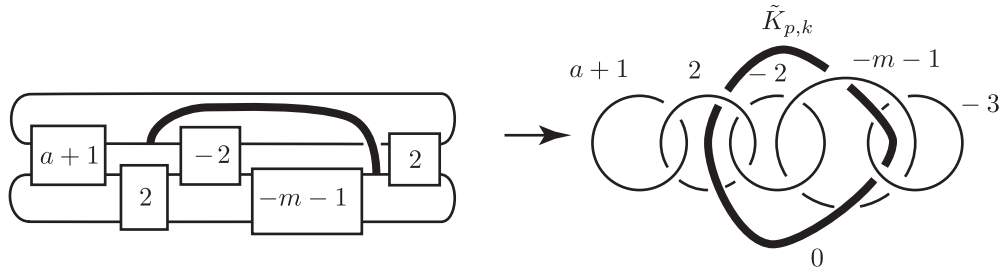

FIGURE 32. K type simple (1,1)-knot $\tilde{K}_{p,k}$ ($m \in \mathbb{Z}$, $a \in \mathbb{Q}$).

APPENDIX 3

In Appendix, we describe families of the knot diagrams $K_{p,k}$ in Seifert manifolds. Attaching 0-framed meridian for the last diagrams in figures in Appendix 2 and deforming the diagrams other than the 0-framed meridian into the form of the Seifert structure, we obtain the knot diagrams (the first picture in Appendix 3). Then we start Kirby calculus for the surgery diagrams and obtain lens spaces (FIGURE 33, 35, 37, 38, 40, 42 and 44). These calculus easily extend to some Seifert surgeries (including lens surgeries) over Seifert manifolds (e.g., including Brieskorn homology spheres or graph homology spheres). See FIGURE 34, 36, 39, 41, 43 and 45.

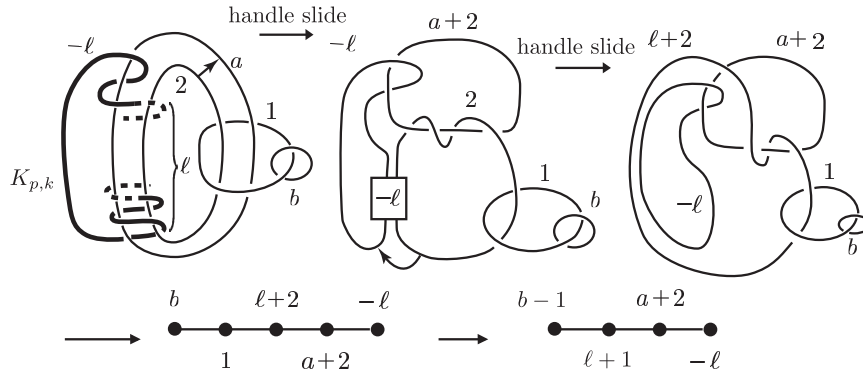

FIGURE 33. A type $K_{p,k}$ (thickened line) for $a \in \mathbb{Z}$, $b \in \mathbb{Q}$ and the surgery calculus move to a lens space. The cases of $(a, b) = (3, 6 \pm 1/n)$ and $(2(2s+1) \pm 1, (2s+1)/2)$ correspond to lens surgeries with A_1 and A_2 types in $\Sigma(2, 3, 6n \pm 1)$ and $\Sigma(2, 2s+1, 2(2s+1) \pm 1)$.

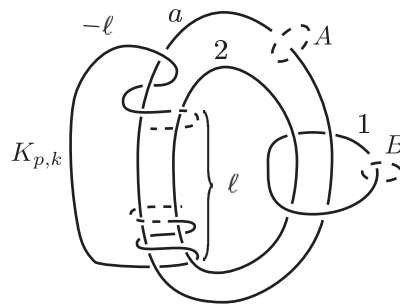

FIGURE 34. The diagram of extended A type Dehn surgery along K .

Acknowledgements: This result is based on my talk presented by workshop "Topology of Knots X" at Tokyo Woman's Christian University in 2007. The author is grateful for giving me the opportunity to talk in the conference. The motivation to write this paper is a private communication [6] with Joshua Greene at Gökova Geometry/Topology Conference 2011 as written as a private communication in [5]. The author is grateful for him with respect to this point. We discuss the lens space surgery in $\Sigma(2, 5, 7)$ yielding $L(17, 15)$ in Proposition 1.15. In 8 years after that, I received the similar questions about the private discussion from Daniel Ruberman and Kyungbae Park independently. It would be possibly somehow worthy that such computation and results are available. The author is so grateful that their

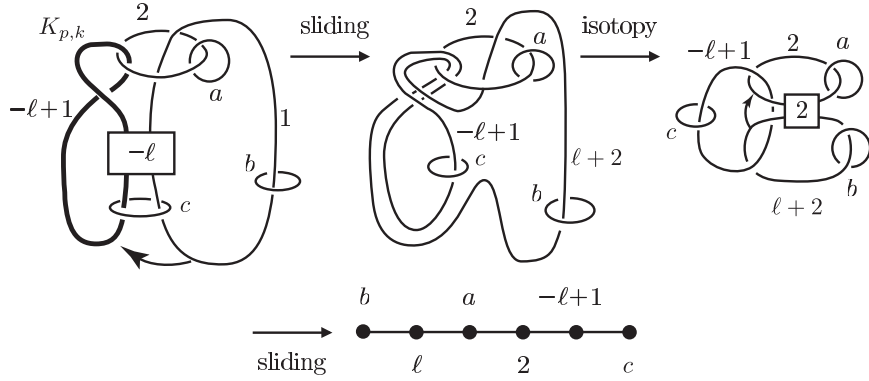

FIGURE 35. B type $K_{p,k}$ ($a \in \mathbb{Z}$ and $b, c \in \mathbb{Q}$) and the surgery calculus move to a lens space. The case of $(a, b, c) = (-1, 5, 2)$ or $(a, b, c) = (-1, 2, 5)$ is B type surgery in $\Sigma(2, 3, 5)$.

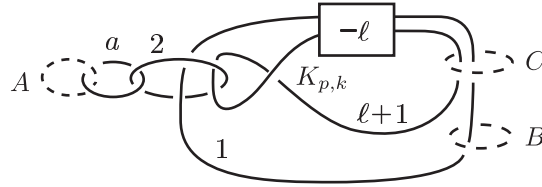

FIGURE 36. The diagram of extended B type Dehn surgery along K .

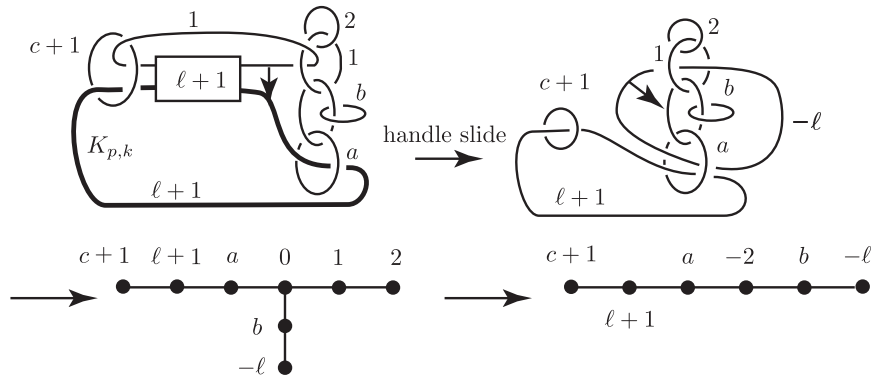

FIGURE 37. CDE type $K_{p,k}$ ($a, b \in \mathbb{Z}$ and $c \in \mathbb{Q}$) and surgery calculus to a lens space. The cases of $(a, b, c) = (1, 2, 5), (2, 1, 5), (1, 4, 3), (4, 1, 3), (2, 5, 1), (5, 2, 1)$ are C_1, C_2, D_1, D_2, E_1 and E_2 type surgeries in $\Sigma(2, 3, 5)$.

communications give the opportunity to write this paper. In particular, K. Park gave the opportunity to talk in KIAS topology seminar in 2016 spring. The author thanks them for reminding me the computation. The author also thanks anonymous referees for correcting my first manuscript so detailed.

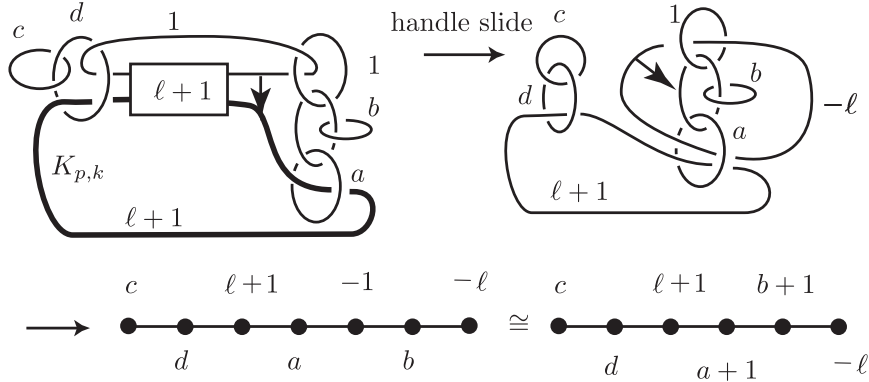

FIGURE 38. FG H type $K_{p,k}$ and surgery calculus to a lens space. The cases of $d = 2$ and $\{a, b, c\} = \{2, 3, 5\}$ are FG H type surgeries in $\Sigma(2, 3, 5)$.

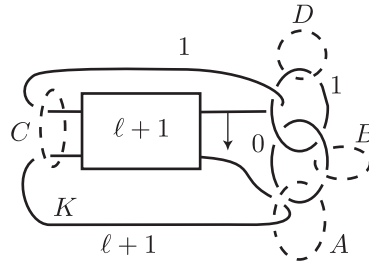

FIGURE 39. The diagram of extended CDE and FG H type Dehn surgery along K .

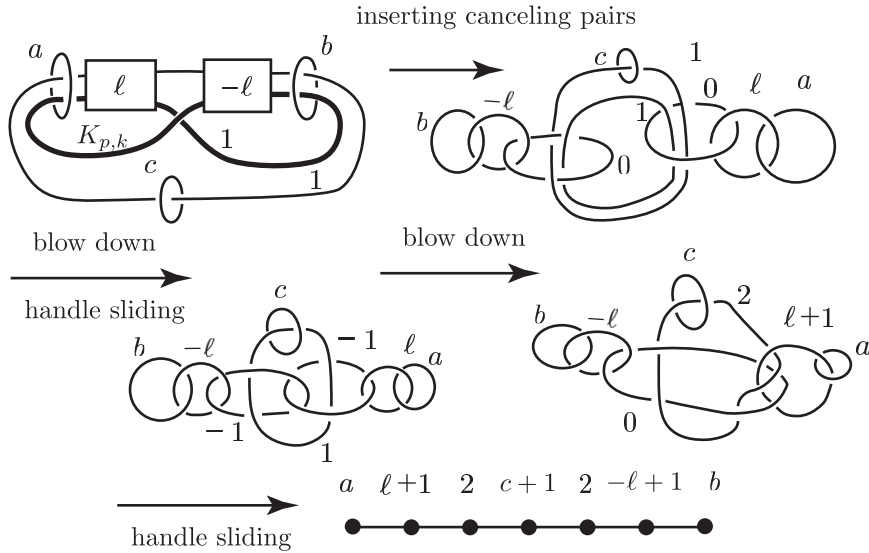

FIGURE 40. I type $K_{p,k}$ ($a, b \in \mathbb{Q}, c \in \mathbb{Z}$) and surgery calculus to a lens space. The cases of $\{a, b, c\} = \{5, 3, 2\}$ are I_1, I_2 and I_3 type knots in $\Sigma(2, 3, 5)$.

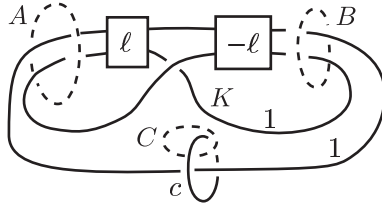

FIGURE 41. The diagram of extended I type Dehn surgery along K .

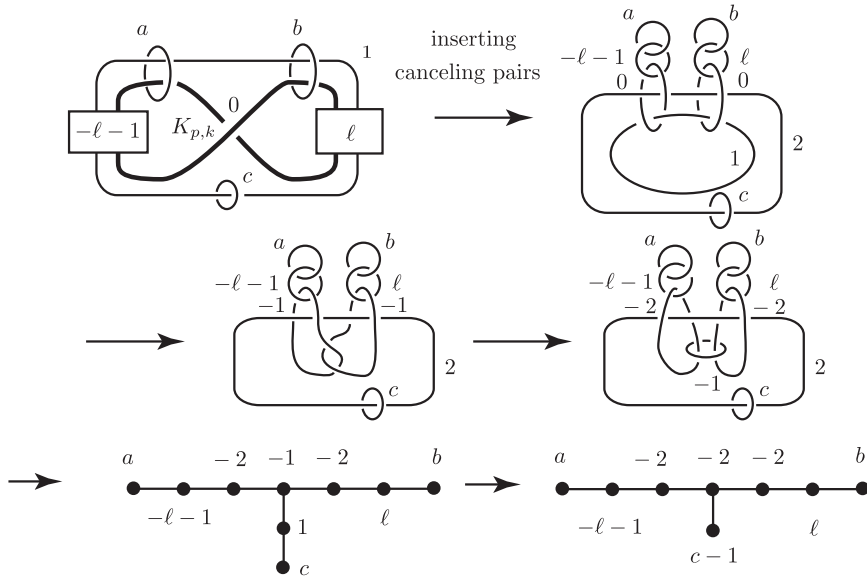

FIGURE 42. J type $K_{p,k}$ ($a, b \in \mathbb{Q}$ $c = 2$) and surgery calculus to a lens space. The cases of $\{a, b\} = \{3, 5\}$ and $c = 2$ are J type surgeries in $\Sigma(2, 3, 5)$.

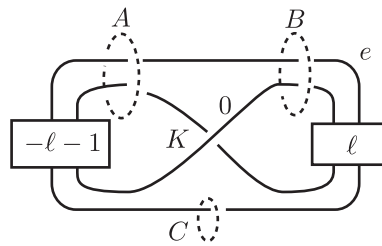

FIGURE 43. Extended J type Dehn surgery.

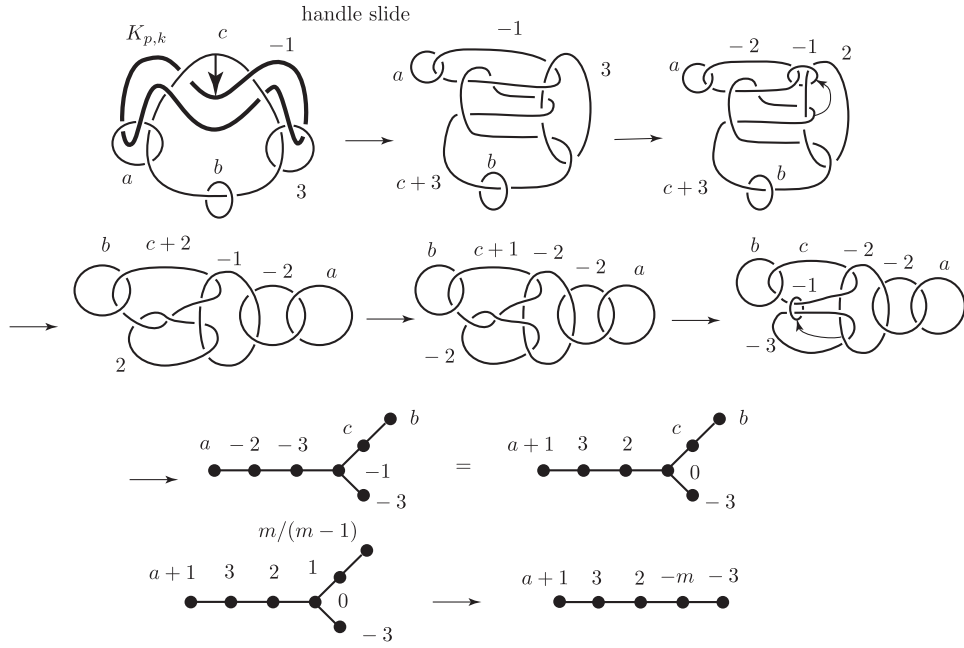

FIGURE 44. K type $K_{p,k}$ and the surgery calculus to a lens space. The case of $(a, b, c) = (5, 2, 1)$ is K type surgery in $\Sigma(2, 3, 5)$.

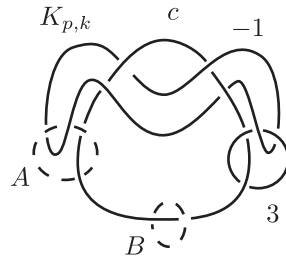

FIGURE 45. The diagram of extended K type Dehn surgery along K .

REFERENCES

- [1] S. Akbulut, and K. Larsen, *Brieskorn spheres bounding rational balls*, Proc. Amer. Math. Soc. **146**(2018), 1817–1824.
- [2] S. Akbulut and R. Kirby, *Mazur manifolds*, Mich. Math. J. **26** (1979) 259–284.
- [3] J. Berge, *Some knots with surgeries yielding lens spaces*, arXiv:1802.09722.
- [4] A. Deruelle, K. Miyazaki and K. Motegi, *Networking Seifert Surgeries on Knots*, Memoirs of the American Mathematical Society No. 1021.
- [5] J. Greene, *The lens space realization problem*, Annals of Mathematics 177 (2): 449–511.
- [6] J. Greene, *Private communication*, The 18th Gökova Geometry Topology conference, 2011.
- [7] R. Kirby, *Problems in low-dimensional topology*, in Geometric Topology (W. Kazez ed.), AMS/IP Stud. Adv. Math. vol. 2.2, Amer. Math. Soc., 1997, pp. 35–473.
- [8] Y. Matsumoto, S. Yamada, *On the Resolution diagrams of the Brieskorn singularities $(2, q, r)$ of type II*, Can. J. Math. Vol. XXXV. No.6. 1983. pp 1049–1058.
- [9] J. M. Montesinos, W. Whitten, *Constructions of two-fold branched covering spaces*, Pacific J. Math. Volume **125**, no. 2 (1986), 415–446.
- [10] P. Orlik, *Seifert manifolds*, Lecture Notes in Mathematics 291, Springer (1972).
- [11] J. Rasmussen, *Lens space surgeries and L-space homology spheres*, arXiv:0710.2531.
- [12] T. Saito, *Dehn surgery and $(1,1)$ -knots in lens spaces*, topol. appl. 154(2007)1502–1515.
- [13] N. Saveliev *Invariants of homology 3-spheres*, Encyclopaedia of Mathematical Sciences 140, Springer (2002).
- [14] M. Tange, *Lens spaces given from L-space homology spheres*, Experiment. Math. 18 (2009), no. 3, 285–301.
- [15] M. Tange, *On the non-existence of L-space surgery structure*, Osaka J. Math. 48 (2011), no. 2, 541–547.
- [16] M. Tange, *A complete list of lens spaces constructed by Dehn surgery I*, arXiv:1005.3512.

INSTITUTE OF MATHEMATICS, UNIVERSITY OF TSUKUBA, 1-1-1 TENNODAI, TSUKUBA, IBARAKI 305-8571, JAPAN

E-mail address: `tange@math.tsukuba.ac.jp`